

# SERVICE MANUAL

PURE POWER DC STEREO RECEIVER

**SANSUI G-5700**  
**G-6700**  
**G-7700**

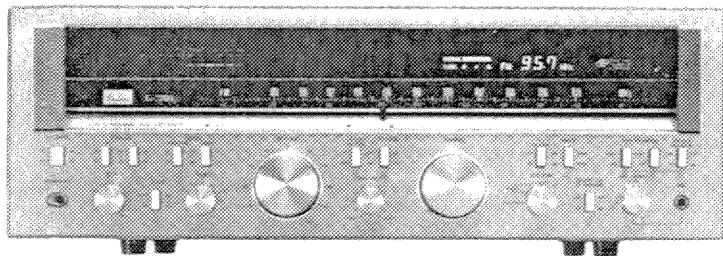

SANSUI ELECTRIC CO., LTD.

## SPECIFICATIONS

- ◆ Audio section
- <G-5700>
- ◆ Power output  
 Min. RMS, both channels driven, from 20 to 20,000 Hz, with no more than 0.03 % total harmonic distortion.  
 75 watts per channel into 8 ohms  
 Load impedance . . . . . 8 ohms
- <G-6700>
- ◆ Power output  
 Min. RMS, both channels driven, from 20 to 20,000 Hz, with no more than 0.025 % total harmonic distortion.  
 90 watts per channel into 8 ohms  
 Load impedance . . . . . 8 ohms
- <G-7700>
- ◆ Power output  
 Min. RMS, both channels driven, from 20 to 20,000 Hz, with no more than 0.025 % total harmonic distortion.  
 120 watts per channel into 8 ohms  
 Load impedance . . . . . 8 ohms
- <G-5700/G-6700>
- ◆ Intermodulation distortion (70 Hz : 7 kHz = 4:1 SMPTE method) . . . . . less than 0.03 % at rated power output
- ◆ Frequency response (at 1 watt)  
 Overall (from TAPE/AUX) . . . . . 5 to 75,000 Hz, +0.2 dB, -2.0 dB  
 Power amplifier section . . . . . DC to 200,000 Hz, +0 dB, -3.0 dB
- <G-7700>
- ◆ Intermodulation distortion (70 Hz : 7 kHz = 4:1 SMPTE method) . . . . . less than 0.025 % at rated power output
- ◆ Frequency response (at 1 watt)  
 Overall (from TAPE/AUX) . . . . . 5 to 75,000 Hz, +0.2 dB, -2.0 dB  
 Power amplifier . . . . . DC to 200 kHz, +0 dB, -3.0 dB
- <G-5700>
- ◆ Total harmonic distortion . . . . . less than 0.03 % at or below rated min. RMS power output
- ◆ Rise time . . . . . 1.4  $\mu$ sec
- ◆ Slew rate . . . . . 56 V/ $\mu$ sec
- <G-6700/G-7700>
- ◆ Total harmonic distortion . . . . . less than 0.025 % at or below rated min. RMS power output
- ◆ Rise time . . . . . 1.4  $\mu$ sec
- ◆ Slew rate . . . . . 60 V/ $\mu$ sec
- <G-5700/G-6700>
- ◆ RIAA curve deviation (PHONO, 30 Hz to 15 kHz) . . . . . +0.2 dB, -0.2 dB
- ◆ Damping factor (20 Hz to 20 kHz, both channels driven) . . . . . 50 into 8 ohms
- ◆ Input sensitivity and impedance (at 1 kHz)  
 PHONO . . . . . 2.5 mV/47 kilohms  
 (Max. input capability: 210 mV at 1 kHz, less than 0.1 % total harmonic distortion)  
 MIC . . . . . 6 mV/10 kilohms  
 TAPE-1, 2 PLAY, TAPE/AUX . . . . . 150 mV/47 kilohms
- ◆ Output level (at 1 kHz)  
 TAPE-1, 2 REC . . . . . 150 mV
- ◆ Hum and noise (short-circuit, A-network)  
 PHONO . . . . . 78 dB  
 TAPE-1, 2 PLAY, TAPE/AUX . . . . . 95 dB
- ◆ Channel separation (at 1 kHz)  
 PHONO . . . . . 55 dB  
 TAPE-1, 2 PLAY, TAPE/AUX . . . . . 65 dB
- <G-7700>
- ◆ RIAA curve deviation (PHONO, 20 Hz to 20 kHz) . . . . . +0.2 dB, -0.2 dB
- ◆ Damping factor (20 Hz to 20 kHz, both channels driven) . . . . . 50 into 8 ohms
- ◆ Input sensitivity and impedance (at 1 kHz)  
 PHONO-1, 2 . . . . . 2.5 mV/47 kilohms  
 (Max. input capability: 250 mV at 1 kHz, less than 0.1 % total harmonic distortion)  
 MIC . . . . . 6 mV/10 kilohms  
 TAPE-1, 2 PLAY, TAPE/AUX . . . . . 150 mV/47 kilohms
- ◆ Output level (at 1 kHz)  
 TAPE-1, 2 REC . . . . . 150 mV
- ◆ Hum and noise (short-circuit, A-network)  
 PHONO-1, 2 . . . . . 78 dB  
 TAPE-1, 2 PLAY, TAPE/AUX . . . . . 95 dB
- ◆ Channel separation (at 1 kHz)  
 PHONO-1, 2 . . . . . 60 dB  
 TAPE-1, 2 PLAY, TAPE/AUX . . . . . 65 dB

Specifications

<G-5700>

- Controls
  - BASS . . . . . ±10 dB at 50 Hz
  - TREBLE . . . . . ±10 dB at 10 kHz
  - SUBSONIC FILTER
    - LOUDNESS (VOLUME control: -30 dB position)
      - 8 dB at 50 Hz
      - 6 dB at 10 kHz
- AUDIO MUTING -20 dB

<G-6700/G-7700>

- Controls
  - BASS . . . . . ±10 dB at 50 Hz
  - TREBLE . . . . . ±10 dB at 10 kHz
  - SUBSONIC FILTER
    - LOUDNESS (VOLUME control: -30 dB position)
      - 8 dB at 50 Hz
      - 6 dB at 10 kHz
- AUDIO MUTING -20 dB

FM sections

<G-5700/G-6700>

- Tuning range . . . . . 88 to 108 MHz
- Usable sensitivity
  - Mono IHF . . . . . 10.8 dBf (1.9 μV)
  - DIN . . . . . 1.2 μV
  - Stereo IHF . . . . . 18 dBf
- 50 dB quieting sensitivity
  - Mono . . . . . 15 dBf
  - Stereo . . . . . 37 dBf
- Signal to noise ratio (at 65 dBf)
  - Mono . . . . . 75 dB
  - Stereo . . . . . 70 dB
- Distortion (at 65 dBf)
  - Mono . . . . . less than 0.13 % at 100 Hz
  - less than 0.1 % at 1,000 Hz
  - less than 0.25 % at 6,000 Hz
  - Stereo . . . . . less than 0.25 % at 100 Hz
  - less than 0.15 % at 1,000 Hz
  - less than 0.25 % at 6,000 Hz

Alternate channel selectivity (at 400 kHz)

- 50 dB
- Capture ratio . . . . . 1.0 dB
- Image response ratio . . . . . 50 dB
- Spurious response ratio . . . . . 70 dB

- IF response ratio . . . . . 90 dB
- Stereo separation . . . . . 35 dB at 100 Hz
- 40 dB at 1,000 Hz
- 28 dB at 10,000 Hz
- Frequency response . . . . . 30 to 15,000 Hz, +0.5 dB, -1.0 dB
- Antenna input impedance
  - 300 ohms balanced
  - 75 ohms unbalanced

<G-7700>

- Tuning range . . . . . 88 to 108 MHz
- Usable sensitivity
  - Mono IHF . . . . . 9.8 dBf (1.7 μV)
  - DIN . . . . . 1.0 μV
  - Stereo IHF . . . . . 17 dBf
- 50 dB quieting sensitivity
  - Mono . . . . . 14 dBf
  - Stereo . . . . . 36 dBf
- Signal to noise ratio (at 65 dBf)
  - Mono . . . . . 76 dB
  - Stereo . . . . . 71 dB
- Distortion (at 65 dBf)
  - Mono . . . . . less than 0.1 % at 100 Hz
  - less than 0.1 % at 1,000 Hz
  - less than 0.25 % at 6,000 Hz
  - Stereo . . . . . less than 0.23 % at 100 Hz
  - less than 0.15 % at 1,000 Hz
  - less than 0.23 % at 6,000 Hz
- Alternate channel selectivity (at 400 kHz)
  - 70 dB
- Capture ratio . . . . . 1.0 dB
- Image response ratio . . . . . 70 dB
- Spurious response ratio . . . . . 90 dB
- IF response ratio . . . . . 95 dB
- Stereo separation . . . . . 35 dB at 100 Hz
- 42 dB at 1,000 Hz
- 30 dB at 10,000 Hz
- 25 dB from 30 to 15,000 Hz
- Frequency response . . . . . 30 to 15,000 Hz, +0.5 dB, -1.0 dB
- Antenna input impedance
  - 300 ohms balanced
  - 75 ohms unbalanced

AM section

- <G-5700/G-6700/G-7700>
- Tuning range . . . . . 530 to 1,600 kHz
- Usable sensitivity (bar antenna)
  - 50 dB/m (300 μV/m)

- Selectivity . . . . . 33 dB
- Signal to noise ratio . . . . . 46 dB
- Distortion (at 30 % Modulation, 80 dB/m)
  - less than 0.5 %

Others

<G-5700>

- Power requirements
  - Power voltage . . . . . 100, 120, 220, 240 V (50/60 Hz)
  - For U.S.A. and Canada
    - 120 V (60 Hz)
- Power consumption
  - Rated consumption
    - 400 watts 450 VA
- Dimensions . . . . . 465 mm (18-5/16") W
- 177 mm (7") H
- 405 mm (16") D
- Weight . . . . . 13.8 kg (30.4 lbs) net
- 16.0 kg (35.3 lbs) packed

<G-6700>

- Power requirements
  - Power voltage . . . . . 100, 120, 220, 240 V (50/60 Hz)
  - For U.S.A. and Canada
    - 120 V (60 Hz)
- Power consumption
  - Rated consumption
    - 330 watts 420 VA
- Dimensions . . . . . 505 mm (19-15/16") W
- 182 mm (7-3/16") H
- 442 mm (16-5/8") D
- Weight . . . . . 16.1 kg (39.7 lbs) net
- 18.4 kg (45.2 lbs) packed

<G-7700>

- Power requirements
  - Power voltage . . . . . 100, 120, 220, 240 V (50/60 Hz)
  - For U.S.A. and Canada
    - 120 V (60 Hz)
- Power consumption
  - Rated consumption
    - 430 watts 540 VA
- Dimensions . . . . . 505 mm (19-15/16") W
- 182 mm (7-3/16") H
- 422 mm (16-5/8") D
- Weight . . . . . 18.0 kg (39.7 lbs) net
- 20.5 kg (45.2 lbs) packed

\* Design and specifications subject to changes without notice for improvements.

# 1. BLOCK DIAGRAM

## • G-5700/G-6700/G-7700 Tuner & Digitally Quartz Locked Section

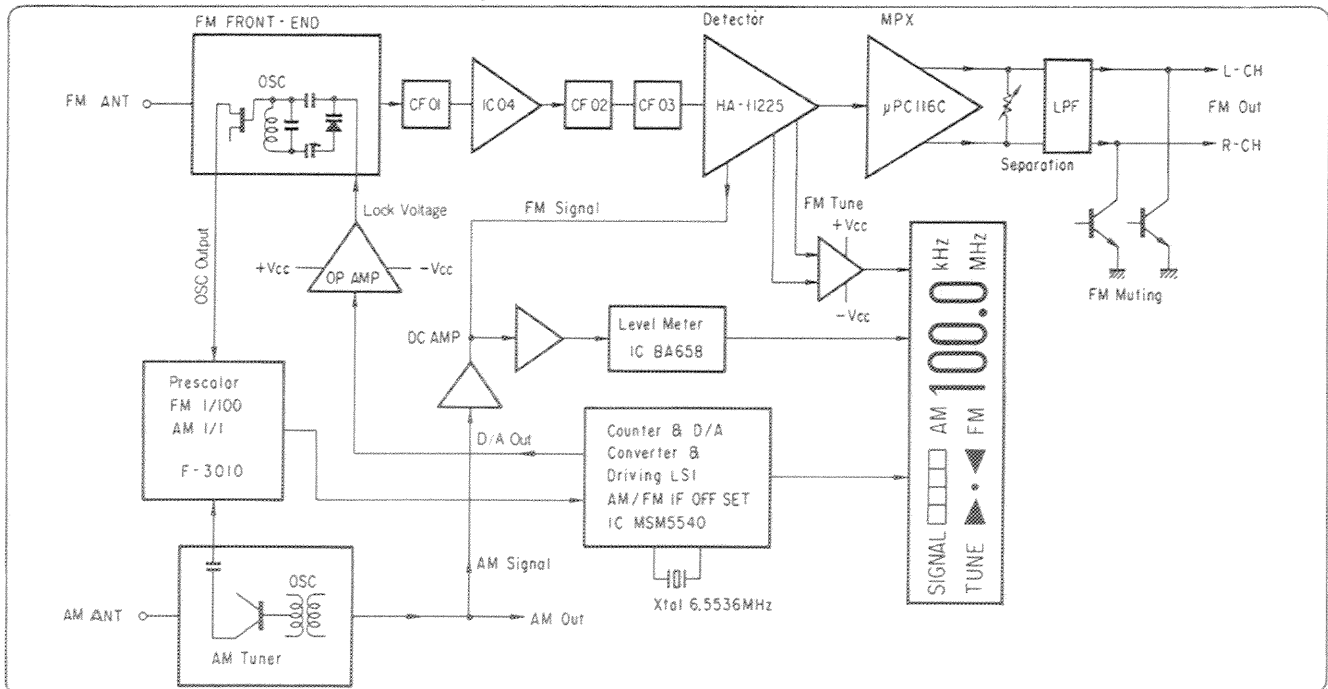

• G-6700/G-7700 Audio Section

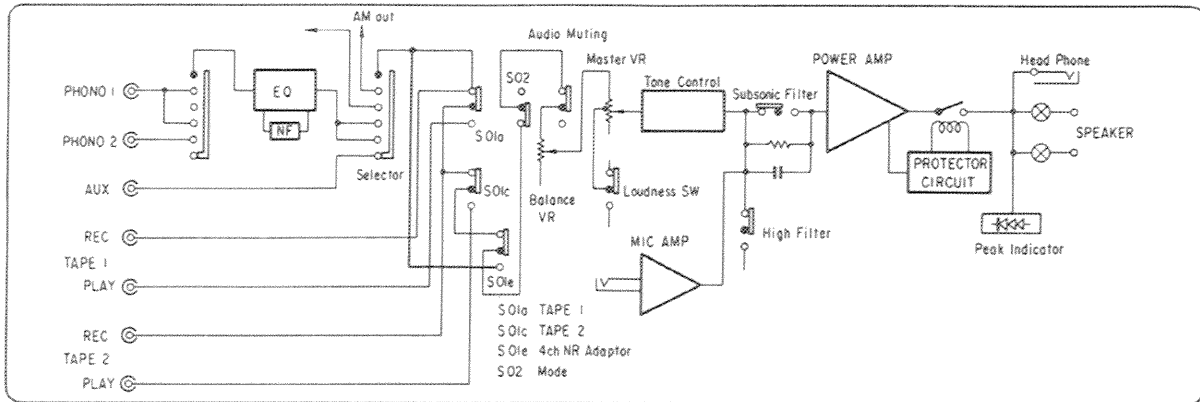

• G-5700 Audio Section

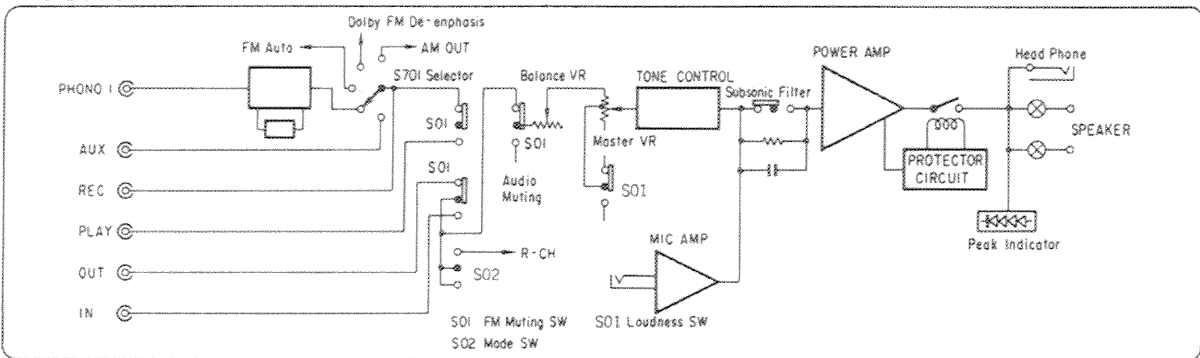

## 2. OPERATION OF PEAK POWER INDICATOR

Fig. 2-1

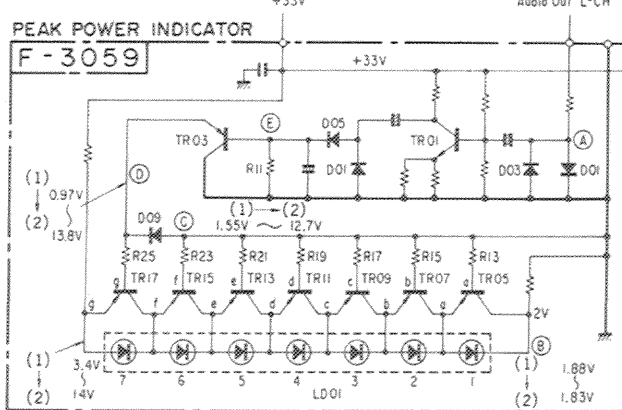

Note: (1) In case no LED lighting (2) In case of all LEDs lighting

Fig. 2-2



Fig. 2-3

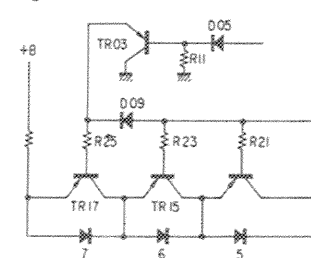

### 2-1. In case no LED lighting

- 1) TR17, R25, TR03 & R11 on F-3059 regarded as a series circuit and a voltage applied to the circuit. TR17 and TR03 are equivalent to diodes connected in forward direction that a current flows into this circuit as Fig. 2-2.
- 2) TR17 being ON, a voltage is applied to the TR15 emitter and a current flows into a circuit composed of TR17, TR15, R23, D09, TR03, and R11 as Fig. 2-3.
- 3) As the bias voltage added to TR03 is the lowest, during no input signal, the maximum current flows and turn on the transistors from TR17 to TR05.
- 4) When every transistor is ON, a currents flowing LEDs are belittled that LEDs would not shine.

### 2-2. In case only one LED lighting

- 1) If input signal of about 0.28V (0.01W) is applied from audio-out, this signal is fed to TR03 as a base bias voltage through TR01 and D05. This bias voltage rises to make the current flowing TR03 little when input voltage of point A is increased.
- 2) Input signal being 0.28V, transistors from TR17 to TR07 are ON and only TR05 turns OFF.
- 3) When TR05 becomes OFF, a current flows into LED of No. 1 and this LED starts lighting.

### 2-3. In case from two to seven LEDs lighting

In the same function as 2-2, transistors TR05, 07, 09 turn OFF successively and all LEDs start lighting. The LED at center is always lighting to be supplied a voltage.

### 3. ADJUSTMENTS

#### 1. FM Adjustment (See Top View on Page 10 & 11)

- Note: 1. Selector . . . . . FM MONO  
 2. FM Muting Switch . . . . . OFF

3. Connection . . . . . Connect the output of genescope to TP through 100 pF ceramic capacitor.

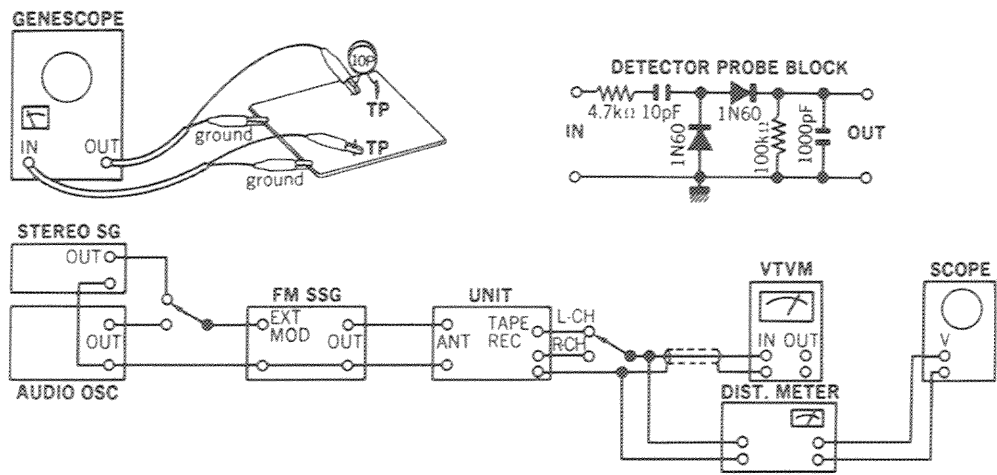

#### (1) FM IF, RF Adjustment and Dial Calibration

\* Before making adjustments of steps 2 ~ 5, run the unit for more than 2 minutes and make the dial pointer go round on the dial scale at once by tuning knob.

STEP	SUBJECT	FEED SIGNAL		MEASURE OUTPUT	ADJUST	ADJUST FOR	REMARKS
		FROM	TO				
1.	IF Coil	Output 90 dB Genescope	TC03 (Front-end)	TP01 Use Detector Probe	T1 (Front-end)	Max. IF waveform	
2.	Discriminator Coil In case of using Genescope	Output 80 dB Genescope	TC03 (Front-end)	TP02	T01 F-2988 T02 F-2988	Steep linearity of S curve Make symmetrical S curve	
	Discriminator Coil In case of using Dist meter	98 MHz ANT Input 65 dBf (59.8 dB) 1000 Hz (100% MOD) FM SSG	ANT terminal 300Ω	REC OUT L or R-CH Dist Meter VTVM & Scope	T01, T02 F-2988 IFT01 (Front-end)	Min THD	
3.	Tune Indicator Adj.	Receive the nearest FM station		Between Terminal 42 & 43 of F-2988 DC Volt Meter	T02 F-2988	DC 0V ± 0.2V	
4.	AFC Voltage Adj.	Same as above		07 Terminal of F-2988 & Front-end DC Volt Meter	VR03 F-3000	DC 7V	Note: Steps 4 & 5 should be performed after confirming that the look indicator does not become luminous when shorting ground and collector of TR15 & base of TR17 on F-3000
5.	98 MHz Dial Calibration	No Input		Dial Pointer	Tuning knob	98 MHz	
		Same as above		Indicator of Display unit	TC06 (Front-end)	98 MHz	
6.	98 MHz RF Adj.	98 MHz ANT Input Minimum value with sine wave 1000 Hz (100% MOD) FM SSG	Same as above	Same as above	<G-5700/6700> TC03, TC04 <G-7700> TC03, TC04, TC05 (Front-end)	Max. Output	
7.	Signal Indicator Volume	98 MHz ANT Input 65 dBf (59.8 dB) 1000 Hz (100% MOD) FM SSG	Same as above		VR01 F-3000	Make every 8 lamps lighting	
		No ANT Input			VR01 F-3000	Make only one lamp lighting	

Note: Confirm the Dial Calibration on the frequencies of 90 MHz & 106 MHz in step 5.

(2) FM STEREO Adjustment

Note: Selector . . . . . FM AUTO

STEP	SUBJECT	FEED SIGNAL		MEASURE OUTPUT	ADJUST	ADJUST FOR	REMARKS
		FROM	TO				
1.	PLL VCO Adj.	98 MHz ANT Input 65 dBf (59.8 dB) FM SSG Pilot 19 kHz (9% MOD) R (or L) Mode 1 kHz + Pilot (100% MOD) STEREO SG	ANT terminal 300Ω	Stereo indicator	VR03 F-2988	Light indicator	Adjust the VR within center of lighting level.
	PLL VCO Adj. In case of using Freq.	98 MHz ANT Input 65 dBf (59.8 dB) FM SSG (No MOD)	Same as above	No. 18 terminal F-2988 Use Freq. counter	VR03 F-2988	19 kHz ± 50 Hz	
2.	Separation	98 MHz ANT Input 65 dBf (59.8 dB) FM SSG Pilot 19 kHz (9% MOD) R Mode 1 kHz + Pilot (100% MOD) STEREO SG	Same as above	OUT L-CH VTVM & Scope	VR02 F-2988	OUT -40 dB	Confirm separation L-CH → R-CH (-40 dB)
3.	Muting level	98 MHz ANT Input 15 dBf (9.8 dB) FM SSG Pilot 19 kHz (9% MOD) SUB 1 kHz + Pilot (100% MOD) STEREO SG	Same as above	Stereo indicator	VR01 F-2988	Muting level 15 dBf (9.8 dB) indicator turns ON	FM MUTING Switch ON

2. AM IF Adjustment & Dial Calibration (See Top View on 10 & 11 Page)

Note: 1. Selector . . . . . AM

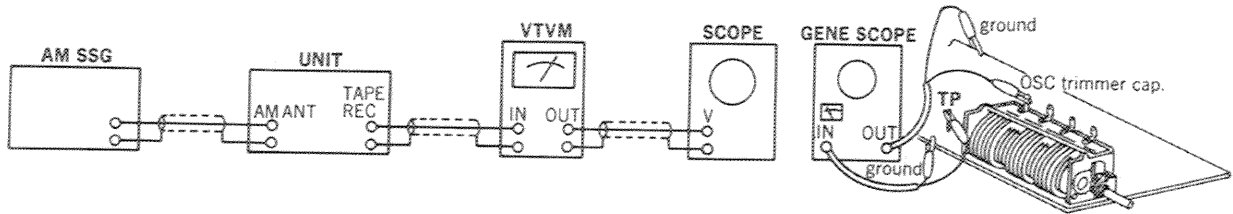

STEP	SUBJECT	FEED SIGNAL		MEASURE OUTPUT	ADJUST	ADJUST FOR	REMARKS
		FROM	TO				
1.	IF Coil	Genescope Output 70 dB	TC01 (Front-end)	TP03 F-2988	T04, T05 F-2988	Max. Output	
2.	600 kHz Dial Calibration	No Input		Dial Pointer	Tuning knob	600 kHz	
		Same as above		Indication of digital display unit	T03 F-2988	600 kHz	
	1400 kHz Dial Calibration	Same as above		Dial Pointer	Tuning knob	1400 kHz	
		Same as above		Indication of digital display unit	TC01 (Front-end)	1400 kHz	
3.	600 kHz RF Adj.	600 kHz ANT Input 50 dB 400 Hz (MOD 30%) AM SSG	Same as above	Same as above	Bar Antenna L701	Same as above	
	1400 kHz RF Adj.	1400 kHz ANT Input 50 dB 400 Hz (MOD 30%) AM SSG	Same as above	Same as above	TC02 (Front-end)	Same as above	
4.	Signal Meter volume	1000 kHz ANT Input 80 dB 400 Hz (MOD 30%) AM SSG	Same as above	Signal indicator lamp	VR02 F-3000	Make every 8 lamps lighting	
		No Input	Same as above	Same as above	VR02 F-3000	Make only one lamp lighting	
5.	9 kHz K notch filter Adj.	9 kHz 5 mV OSC	TP03 F-2988	OUT L or R-CH VTVM & Scope	T06 F-2988	Min. Output	

### 3. Driver Circuit Board Adjustments <G-5700/G-6700/G-7700> (See Top View on Page 10 & 11)

Note: 1. Master Volume . . . . . Minimum  
 2. Room Temperature . . . 18°C ~ 28°C (65°F ~ 83°F)  
 3. For adjustment, run the unit for more than 3 minutes after the power is switched on.

STEP	SUBJECT	MEASURE OUTPUT	ADJUST	ADJUST FOR	REMARKS
1.	DC 0V Adj. L-CH	Speaker terminal (L-CH)	VR01 (L-CH) F-2980	DC 0V ± 5 mV	Before turning ON power switch, set VR01 & VR02 to center position.
2.	DC 0V Adj. R-CH	Speaker terminal (R-CH)	VR02 (R-CH) F-2980		
3.	Bias Current Adj. L-CH	<G-5700/G-6700> Between terminal 85 & Point A (See Top View on Page 10) <G-7700> Between terminal 89 & 87 of F-2980 (Between A & B) (See Top View on Page 11)	VR03 F-2980	DC 5V ± 1 mV	<ul style="list-style-type: none"> <li>Before turning ON power switch, turn VR03 &amp; VR04 fully counter-clockwise.</li> <li>This bias current adjustment converts current value into voltage by Ohms law.</li> </ul>
4.	Bias Current Adj. R-CH	<G-5700/G-6700> Between terminal 86 & Point B (See Top View on Page 10) <G-7700> Between terminal 90 & 88 of F-2980 (Between C & D) (See Top View on Page 11)	VR04 F-2980		

#### • NEW MEASUREMENT FOR FM.

Input signal level under the provision of IHFM-T-200, a new measurement method is indicated by available power ratio "dBf". To obtain approximate available power ratio "dBf", abstract 0.8 from attenuator indication of general FMSG (open load indication type); however, the former measurement, IHFM-T-100 is designated together too.

The way of modulation of IHFM-T-200 is shown below.

	modulation frequency	modulation mode	modulation factor
FM MONO	1000 Hz		100%
FM STEREO	1000 Hz	SUB	Pilot 9% Pilot + SUB 100%

• The relation between the standard input 65 dBf of IHFM-T-200 and the former indication "dB" is shown below.

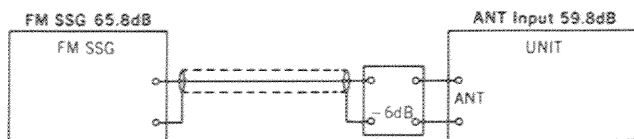

#### • Intermediate frequency of AM Section (See Figs. 3-1 & 3-2).

Since the band pass filter of both 450 kHz type and 455 kHz type are adaptable to the IF stage of these models, pay attention for inserting position of jumper wire and a diode for setting the IF OFFSET ROM value when replacement.

Fig. 3-1.

Intermediate frequency	Stock No. of IF filter, T05 on F-2988	Inserting Position of jumper wire on F-3000	Inserting Position of Diode on F-3000
450 kHz	0910490	X	D23
455 kHz	4230680	Z	D21, D24

#### • Selection of Intermediate Frequencies (FM) (Refer to parts location F-3000 on page 9)

The digital locking point differs with the frequency rank of the ceramic filter used in the F-2988. When the central frequency (shown by a color) of the ceramic filter is changed, the following connection must be made by using jumper wires:

- Unify the color marks of the FM ceramic filters (CF 01 ~ CF 04) on the F-2988 with the same color.
- Select the joints A, B, and C of F-3000 according to color marks as shown in the following table:

Colouring	Intermediate frequency	Connecting Position of Jumper wire on F-3000				Connecting Position of Diode on F-3000			
		A	B	C	Jumper wire Total Q'ty	D26	D25	D24	Diode Total Q'ty
Black	10.64MHz			●	1			●	1
Brown	10.66MHz		●		1		●		1
Blue	10.68MHz		●	●	2		●	●	2
Red	10.70MHz	●			1	●			1
Orange	10.72MHz	●		●	2	●		●	2
Gray	10.74MHz	●	●		2	●	●		2
White	10.76MHz	●	●	●	3	●	●	●	3

Fig. 3-2

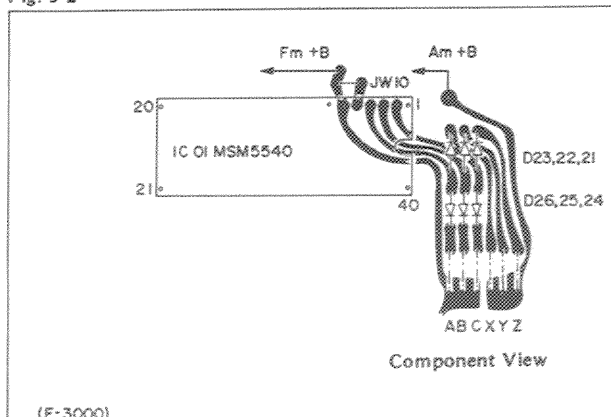

# 4. PARTS LOCATION & PARTS LIST

## 4-1. F-2865 Equalizer Circuit Board (Stock No. 7551551 = G-5700/G-6700) (Stock No. 7551541 = G-7700)

Conductor Side

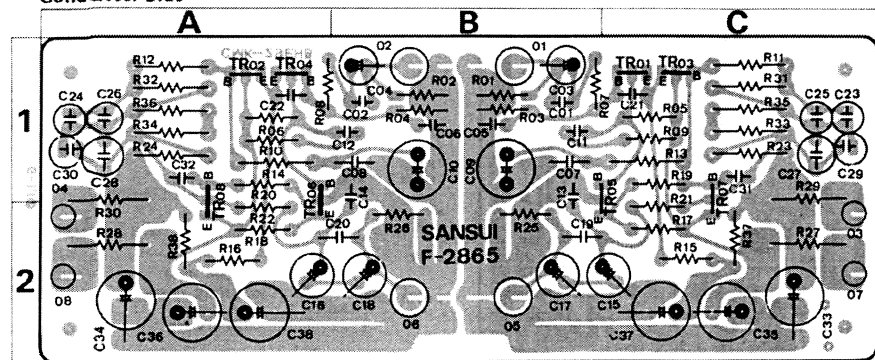

Since some of capacitors and resistors are omitted from parts lists in this Service Manual, refer to the Common Parts List for capacitors & resistors which was appended previously to each Sansui Manual.

### Parts List <G-5700/G-6700>

Parts No.	Stock No.	Description	Position
<b>•Transistor</b>			
TR01, 02	0300900, 1	2SA906 (G), (H)	1C, 1A
TR07, 08	0306740, 1	2SC1845 F, E	1, 2C, 1, 2A
C 25, 26	0620121	120pF 50V P.C.	1C, 1A
R 11, 12	0231101	100Ω 1/2W M.R.	1C, 1A

Parts No.	Stock No.	Description	Position
R 13, 14	0231471	470Ω 1/2W M.R.	1C, 1A
R 23, 24	0210472	4.7kΩ 1/2W N.I.R.	1C, 1A
R 27	0210101	100Ω 1/2W N.I.R.	2C
R 29	0210101	100Ω 1/2W N.I.R.	1C
R 31, 32	0231223	22kΩ 1/2W M.R.	1C, 1A
R 33, 34	0231473	47kΩ 1/2W M.R.	1C, 1A
R 35, 36	0231274	270kΩ 1/2W M.R.	1C, 1A

### Parts List <G-7700>

Parts No.	Stock No.	Description	Position
<b>•Transistor</b>			
TR01, 02	0300900, 1	2SA906 (G), (H)	1C, 1A
TR03, 04	0300900, 1	2SA906 (G), (H)	1C, 1A
TR05, 06	0306550, 1	2SC1775 E, F	1, 2B, 1, 2A
TR07, 08	0306550, 1	2SC1775 E, F	1, 2C, 1, 2A
C 05, 06	0280101	100pF 50V P.C.	1B
C 23, 24	0625122	1200pF 50V P.C.	1C, 1A
C 25, 26	0620391	390pF 50V P.C.	1C, 1A
C 27, 28	0625562	5600pF 50V P.C.	1C, 1A
C 29, 30	0620101	100pF 50V P.C.	1C, 1A
R 23, 24	0210562	5.6kΩ 1/2W N.I.R.	1C, 1A
R 28	0191270	27Ω 1/4W F.R.	2A
R 30	0191270	27Ω 1/4W F.R.	1, 2A
R 31, 32	0231473	47kΩ 1/2W M.R.	1C, 1A
R 33, 34	0231223	22kΩ 1/2W M.R.	1C, 1A
R 35, 36	0231564	560kΩ 1/2W M.R.	1C, 1A

## •G-5700

## 4-2. F-2863 Tone Control Circuit Board (Stock No. 7562901)

Conductor Side

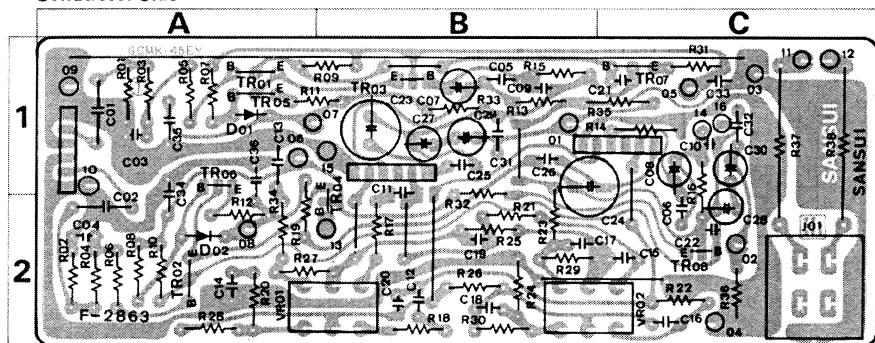

### Parts List

Parts No.	Stock No.	Description	Position
<b>•Transistor</b>			
TR01, 02	0306740, 1	2SC1845 F, E	1A, 2A
TR03, 04	0306740, 1	2SC1845 F, E	1B, 2B
TR05, 06	0306740, 1	2SC1845 F, E	1A
TR07, 08	0301090, 1	2SA992 F, E	1C, 2C
<b>•Diode</b>			
D 01, 02	0340120 0340150	VD1212 MV-12	1A, 2A
R 37, 38	0135221	220Ω 5W Ce.R. Tone Control Volume	1C
VR01, 02	1015360, 1	100kΩ x 2	2B
J 01	2430400	Head Phone Jack	

## •G-6700/G-7700

## 4-3. F-2855 Tone Control Circuit Board (Stock No. 7562861)

Conductor Side

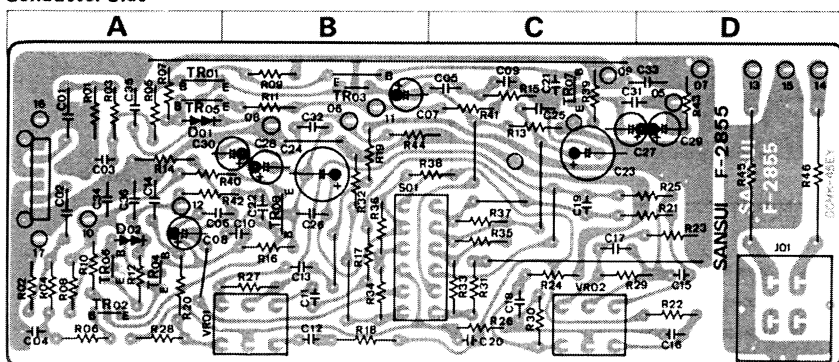

### Parts List

Parts No.	Stock No.	Description	Position
<b>•Transistor</b>			
TR01, 02	0306070, 1	2SC1313 F, G	A
	0306740, 1	2SC1845 F, E	
TR03, 04	0306070, 1	2SC1313 F, G	B, A
	0306740, 1	2SC1845 F, E	
TR05, 06	0306070, 1	2SC1313 F, G	A
	0306740, 1	2SC1845 F, E	
TR07, 08	0301090, 1	2SA992 F, E	C, B
<b>•Diode</b>			
D 01, 02	0340120 0340150	VD1212 MV-12	A
R 45, 46	0135221	220Ω 5W Ce.R.	D
VR01, 02	1015360, 1	100kΩ x 2, Tone Control Volume B.C.	
S 01	1131630, 1	0.3A 45V, Tone Switch	B
J 01	2430400	Head Phone Jack	D

### •Abbreviations

C.R. .... Carbon Resistor	E.L. .... Low Leak Electrolytic Capacitor
S.R. .... Solid Resistor	E.B. .... Bi-Polar Electrolytic Capacitor
Ce.R. .... Cement Resistor	E.BL. .... Low Leak Bi-Polar Electrolytic Capacitor
M.R. .... Metal Film Resistor	Ta.C. .... Tantalum Capacitor
F.R. .... Fusing Resistor	F.C. .... Film Capacitor
N.I.R. .... Non-Inflammable Resistor	M.P. .... Metallized Paper Capacitor
C.C. .... Ceramic Capacitor	P.C. .... Polystyrene Capacitor
C.T. .... Ceramic Capacitor, Temperature Compensation	G.C. .... Gimmi Capacitor
E.C. .... Electrolytic Capacitor	

4-4. F-2980 Power Amplifier Circuit Board (Stock No. 7572341 = G-5700) (Stock No. 7572591 = G-6700)  
 Conductor Side  
 (Stock No. 7572331 = G-7700)

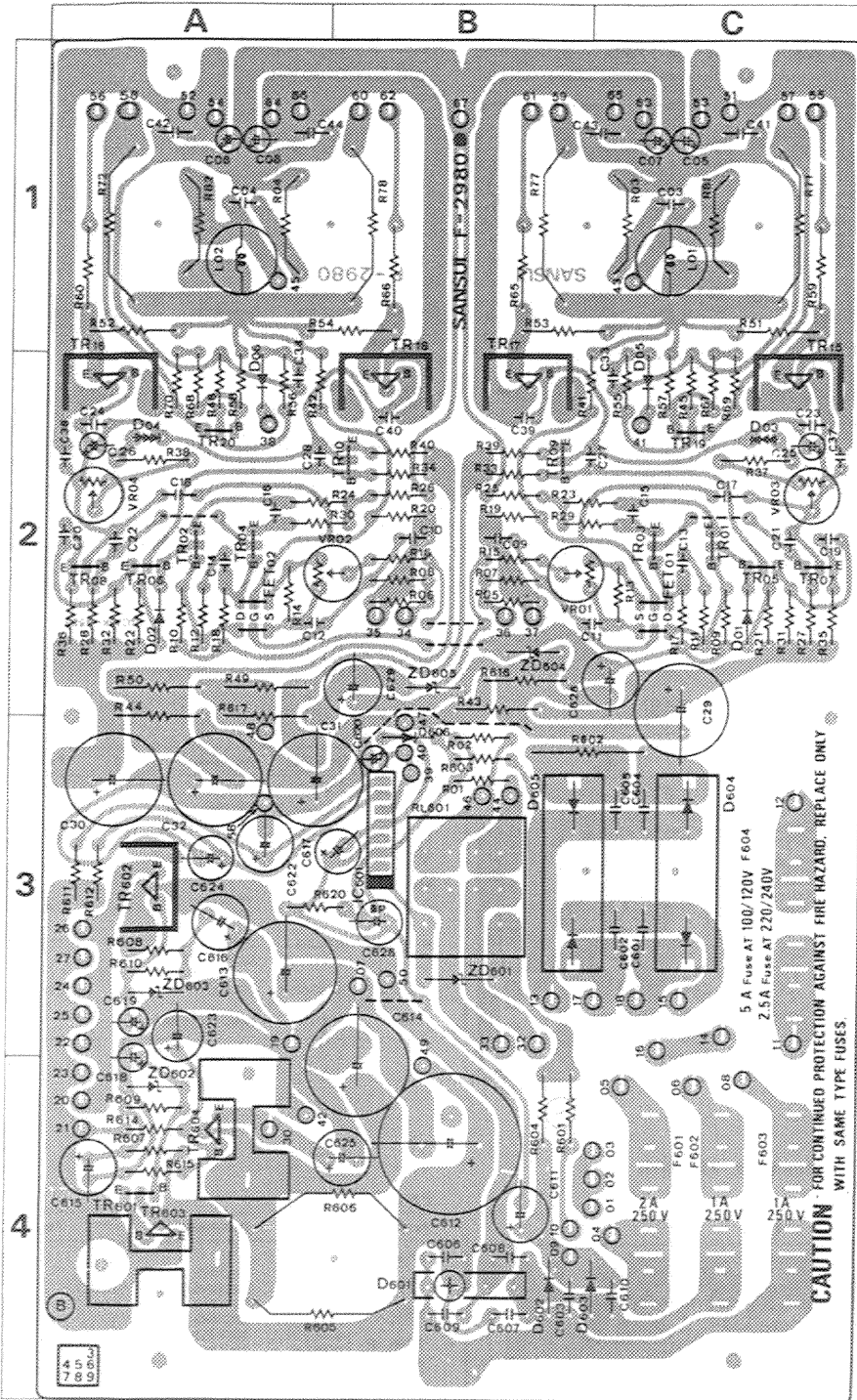

Parts No.	Stock No.	Description	Position
TR 17, 18	0303441, 2	2SB527 D, E <G-5700 only>	2B
	0303371, 2	2SB536 (2) M, L <G-6700 only>	
	0301070, 1	2SA9688 O, Y <G-7700 only>	
TR 19, 20	0301090, 1	2SA992 F, E <G-5700 only>	2C, 2A
	0301030	2SA939B <G-6700/G-7700 only>	
TR 601	0306740, 1	2SC1845 F, E	4A
TR 602	0303232	2SB507V11-AL E	3A
TR 603	0308392, 3	2SD313AL E, F	4A
TR 604	0308393	2SD313AL F	4A
*IC	IC 601	0360900 HA12002	3B
*FET			
FET 01, 02	0370311, 2	2SK129A L, M <G-5700/G-7700 only>	2C, 2A
	0390361, 2	$\mu$ PAB88 L1, L2 <G-6700 only>	
*Diode			
D 01, 02	0311160	1S2473D	2C, 2A
	0311180	1S1588	
D 05, 06	0311160	1S2473D	2C, 2A
	0311180	1S1588	
D 601	0311700	RB-152	4B
D 602	0310350	10D2	4B
D 603	0310350	10D2	4C
D 604	0311310	SS-5	3C
D 605	0311320	SS-5R	3B
D 606	0310350	10D2	3B
ZD 601	0317170	RD 24F (B)	3B
	0317220	RD 30F (C)	
ZD 602	0317230	<G-5700/G-6700 only> RD 33F (B)	4A
	0317220	<G-7700 only> RD 30F (C)	
ZD 603	0317220	<G-5700/G-6700 only> RD 30F (C)	3A
	0317230	<G-7700 only> RD 33F (B)	
ZD 604, 605	0317110	RD 18F (B)	2B
	0317120	RD 18F (C)	
ZD 606	0316320	RD13E C	
C 41 - 44	0659804	0.001 $\mu$ F 150V C.C. <G-5700 only>	1C, 1A
	0655103	10000pF 500V C.C. <G-6700/G-7700 only>	
C 601 - 612	0655472	4700pF 500V C.C.	3C
	0655472	4700pF 500V C.C.	3C
	0655472	4700pF 500V C.C.	4B
	0655472	4700pF 500V C.C.	3C
	0655472	4700pF 500V C.C.	3C
	0655472	4700pF 500V C.C.	4B
	0655472	4700pF 500V C.C.	4B
	0655472	4700pF 500V C.C.	4B
	0655472	4700pF 500V C.C.	4B
	0655472	4700pF 500V C.C.	4C
	0655472	4700pF 500V C.C.	4C
	0549207	1000 $\mu$ F 63V E.C.	4B
R 03, 04	0212479	4.7 $\Omega$ 2W N.I.R.	1C, 1A
	0212109	1 $\Omega$ 2W N.I.R.	1C, 1A
	0201122	1.2k $\Omega$ 1W N.I.R.	4B
	0201102	1.0k $\Omega$ 1W N.I.R.	4B
R 605, 606	0185391	390 $\Omega$ 5W Ce.R. <G-5700 only>	4B
	0135271	270 $\Omega$ 5W Ce.R. <G-6700 only>	
R 616, 617	0185331	330 $\Omega$ 5W Ce.R. <G-7700 only>	2B, 2, 3A
	0212182	1.2k $\Omega$ 1W N.I.R. <G-5700 only>	
L 01, 02	0212182	1.8k $\Omega$ 2W N.I.R. <G-5700 only>	2B, 2, 3A
	4290370	1 $\mu$ H Filter Coil	
RL 601	1150400 1150480		3B
VR 01, 02	1034150	100 $\Omega$ B, DC 0V Adjust	2B
VR 03, 04	1034150	100 $\Omega$ B, Bias Current Adjust	2C, 2A
F 601	0432240	2A 250V AC Fuse	4C
F 602, 603	0432220	1A 250V AC Fuse <G-6700 only>	4C
F 602, 603	0432240	2A 250V AC Fuse <G-6700 only>	4C
	0432260	3A 250V AC Fuse <G-5700 only>	
F 604	0432300	6A 125V AC Fuse <G-5700 only>	3C
F 604	0431320	10A 250V AC Fuse <G-7700 only>	3C
F 604	0431270	4A 250V AC Fuse <G-6700 only>	3C
F 604	0432500	7A 125V AC Fuse <G-6700 only>	3C

Parts List <G-5700/7700>

Parts No.	Stock No.	Description	Position	Parts No.	Stock No.	Description	Position
*Transistor							
TR 01, 02	0306740, 1	2SC1845 F, E	2C, 2A	TR 09, 10	0306281, 2	2SC1735 D, E <G-6700 only>	2B
TR 03, 04	0306740, 1	2SC1845 F, E	2C, 2A		0306680, 1	2SC2071 B, V <G-6700/G-7700 only>	
TR 05, 06	0300721, 2	2SA850 D, E <G-5700 only>	2C, 2A	0308611, 2	2SD357 D, E <G-5700 only>	TR 15, 16	2C, 2A
	0301030, 1	2SA939 B, V <G-6700/G-7700 only>		0308531, 2	2SD381 (2) M, L <G-6700 only>		
TR 07, 08	0300721, 2	2SA850 D, E <G-5700 only>	2C, 2A	0308720	2SC22388 O, Y. <G-7700 only>		
	0301030, 1	2SA939 B, V <G-6700/G-7700 only>	2C, 2A				



4-5. F-2988 Tuner Circuit Board (Stock No. 7522281 = G-5700/G-6700)  
Conductor Side (Stock No. 7572261 = G-7700)

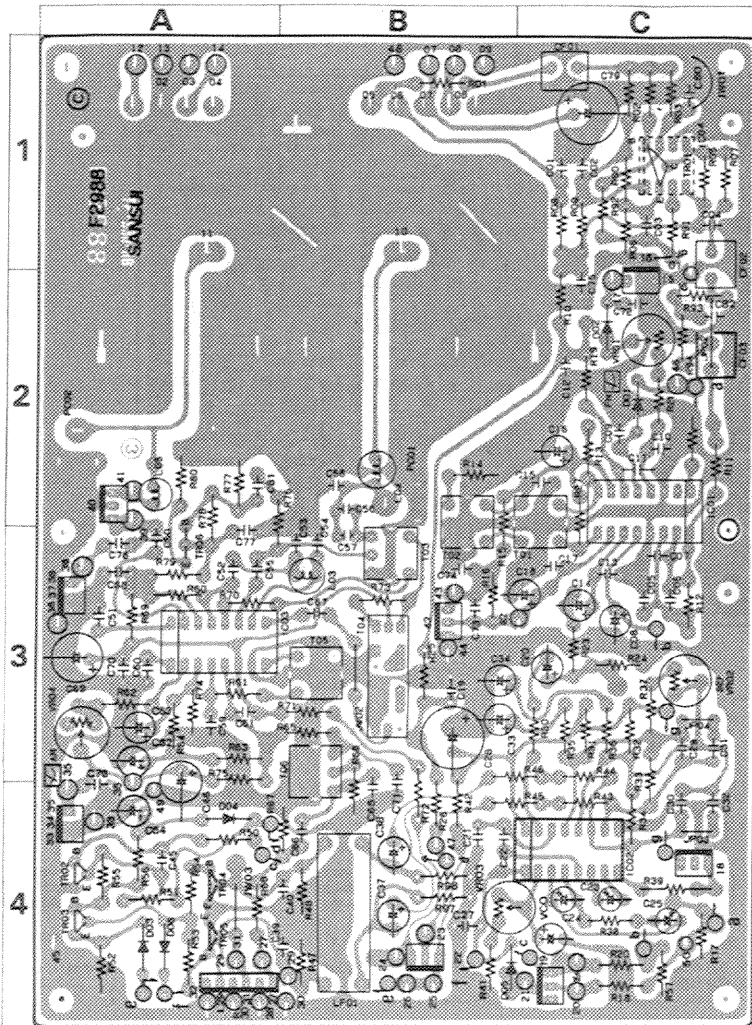

Parts List <G-5700/G-6700/G-7700>

Parts No.	Stock No.	Description	Position
<b>•Transistor</b>			
TR01	0306341, 2	2SC1674 L, K <G-5700/G-6700 only>	1C
TR02	0306740, 1	2SC1845 F, E	4A
TR03	0301090, 1	2SA992 F, E	4A
TR04, 05	0306581, 2	2SC1634-6, 7	4A
TR06	0306341, 2	2SC1674 L, K	3A
<b>•IC</b>			
IC 01	0360930	HA11225	2C
IC 02	0360990	μPC1161C	4C
IC 03	0360800	LA1240	3A
IC 04	0360510	LA1222 <G-7700 only>	1C
<b>•Diode</b>			
D 01	0311160	1S2473D	2C
D 03 ~ 06	0311160	1S2473D	4A, C
C 21	0622471	4700pF 125V P.C.	4B
C 23	0573228	0.22μF 35V T.C.	4C
C 24	0573159	1.5μF 35V T.C.	4C
C 25	0573339	3.3μF 35V T.C.	4C
C 26	0629006	470pF 50V P.C.	
C 31, 32	0622561	560pF 125V P.C.	3C, 4C
C 56	0622391	390pF 125V P.C.	2B
C 57	0669210	10pF 50V C.C.	3B
C 58	0669406	22pF 50V C.C.	2B
C 901	0669502	2pF 50V C.C.	
L 03	4900110	100μH Inductor	3B
L 04, 05	4900140	1μH Inductor	2B, 2A
T 01	4236230	FM Detector Coil	2C
T 02	4236240	FM Detector Coil	2B
T 03	4220710	OSC Coil	3B
T 03	4220730	OSC Coil	3B
T 04	0910490	Filter 450 kHz	3B
T 05	4230620	IF Coil 455 kHz	3B
T 06	0910450	Filter Coil	3B
CF 01, 02	0990060	Ceramic Filter <G-5700/G-6700 only>	1C
CF 01 ~ 03	0910480	Ceramic Filter <G-7700 only>	1C, 2C
LF 01	0910220	Low Pass Filter	4B
VR01	1035150	22kΩB, FM Muting Volume	2C
VR02	1035210	220ΩB, Separation Volume	3C
VR03	1034250	4.7kΩB, PLL VCO Volume	4B
TC 01, 02	1230060	Trimmer <G-7700 only>	
	7510800	Front end Pack	

• G-6700/G-7700

4-6. F-2857 Mic Amp. Circuit Board (Stock No. 7610461)  
Conductor Side

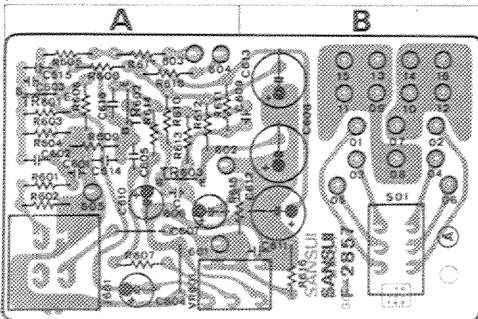

Parts List

Parts No.	Stock No.	Description	Position	Parts No.	Stock No.	Description	Position
<b>•Transistor</b>							
TR 601	0306070, 1	2SC1313 F, G	A	VR601	1090340, 1	20kΩA x 2, mic level volume	A
TR 602	0300470	2SA726 (F)	A	S 01	1131620, 1	Dolby FM De-emphasis Switch	B
TR 603	0306740, 1	2SC1845 F, E	A	J 601	2430400	Mic Jack	A
R 617	0191470	47Ω 1/4W F.R.	A				
R 618	0191470	47Ω 1/4W F.R.	A				

•G-5700

4-7. F-2916 Mic Amp. Circuit Board  
(Stock No. 7610471)

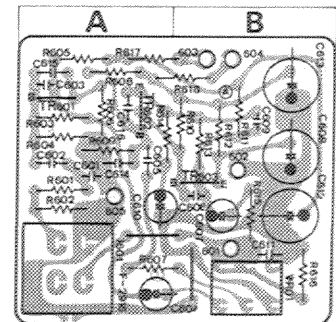

Parts List

Parts No.	Stock No.	Description	Position
<b>•Transistor</b>			
TR 601	0306740, 1	2SC1845 F, E	A
TR 602	0301090, 1	2SA992 F, E	A
TR 603	0306740, 1	2SC1845 F, E	B
R 617	0191470	47Ω 1/4W F.R.	A
R 618	0191470	47Ω 1/4W F.R.	B
VR601	1090340, 1	20kΩA x 2 Mic Level Volume	
J 601	2430400	MIC Jack	A

◆ G-5700/G-6700/G-7700

4-8. F-3000 Digitally Display Circuit Board (Stock No. 7597971)

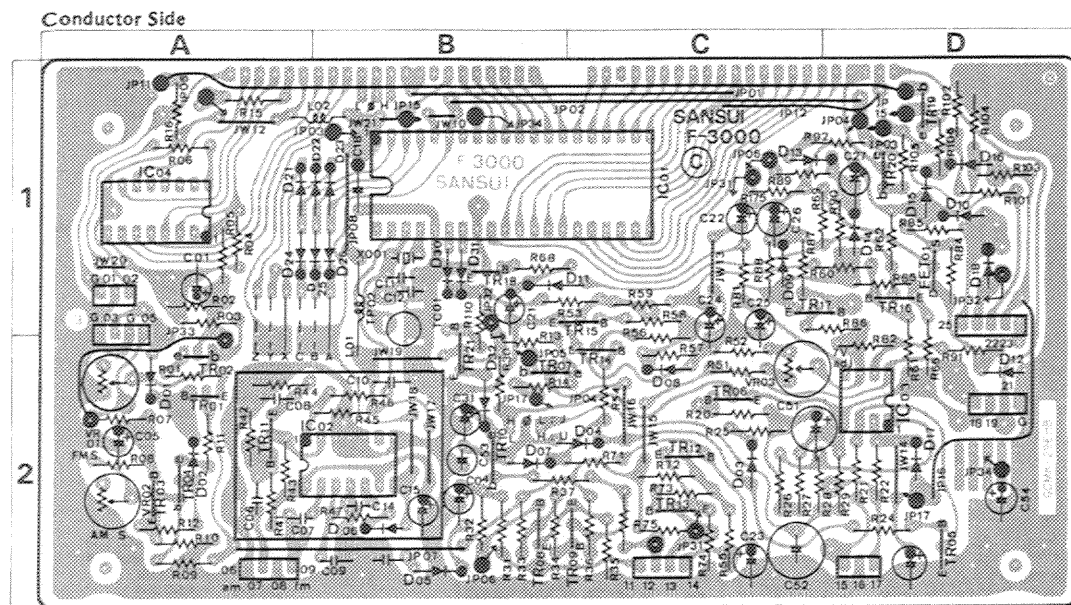

Parts List

Parts No.	Stock No.	Description	Position	Parts No.	Stock No.	Description	Position	Parts No.	Stock No.	Description	Position				
◆ Transistor															
TR01	0305951 ~ 3	2SC945 Q.P.K	2A	TR19	0300510 ~ 2	2SA733A P.O.R	1D	D 23	0311160	1S2473D	1B				
TR02	0300510 ~ 2	2SA733A P.O.R	2A	TR20	0300510 ~ 2	2SA733A P.O.R	1D	D 26	0311160	1S2473D	1B				
TR03	0305951 ~ 3	2SC945 Q.P.K	2A	TR21	0305951 ~ 3	2SC945 Q.P.K	2B	D 30	0311160	1S2473D	1B				
TR04	0300510 ~ 2	2SA733A P.O.R	2A					D 32	0311160	1S2473D	2B				
TR05	0305951 ~ 3	2SC945 Q.P.K	2D	◆ IC											
TR06	0305951 ~ 3	2SC945 Q.P.K	2C	IC 01	0360910	MSM5540RS	1B	C 11	0669508	8pF 50V C.C.	1B				
TR07	0300510 ~ 2	2SA733A P.O.R	2B	IC 03	0360770	NUM4558D	2D	C 12	0661220	22pF 50V C.C.	1B				
TR08	0305951 ~ 3	2SC945 Q.P.K	2B	IC 04	0360830	BA658	1A								
TR09	0305951 ~ 3	2SC945 Q.P.K	2C	◆ FET											
TR10	0300510 ~ 2	2SA733A P.O.R	2B	FET01	0370300 ~ 3	2SK117 O.Y.GR.BL	1D	VR01	1035130	10kΩB, FM Meter Adjust	2A				
TR12	0305951 ~ 3	2SC945 Q.P.K	2C		0370340 ~ 7	2SK163		VR02	1035190	100kΩB, Meter Adjust	2A				
TR13	0305951 ~ 3	2SC945 Q.P.K	2C			K1, K2, L1, L2, M1, M2, N1, N2		VR03	1035110	4.7kΩB, AFC Bias Adjust	2C				
TR14	0305951 ~ 3	2SC945 Q.P.K	2C	◆ Diode											
TR15	0305951 ~ 3	2SC945 Q.P.K	1C	D 02 ~ 10	0311160	1S2473D	1C,2A,B,C	TC01	1230150	30pF Trimmer Capacitor	1B				
TR16	0305951 ~ 3	2SC945 Q.P.K	1D	D 11 ~ 18	0311160	1S2473D	1B,C,D,2D	X001	0930040	Xtal, 6.5536 MHz	1B				
TR17	0305951 ~ 3	2SC945 Q.P.K	1C												
TR18	0305951 ~ 3	2SC945 Q.P.K	1B												

◆ G-5700/G-6700/G-7700

4-9. F-3010 Pre Scaler Circuit Board (Stock No. 7597981)

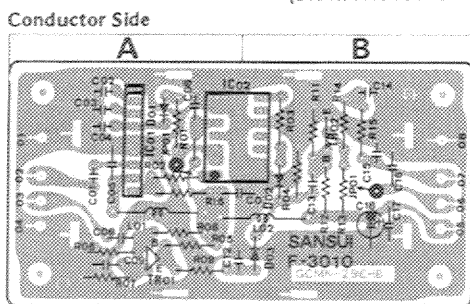

Parts List

Parts No.	Stock No.	Description	Position
◆ Transistor			
TR01	0306341, 2	2SC1674 L, K	A
TR02	0306341, 2	2SC1674 L, K	B
◆ IC			
IC 01	0361130	AN6821	A
IC 02	0361120	SN74LS90N	A
◆ Diode			
D 01	0311160	1S2473D	A
D 02	0311160	1S2473D	B
D 03	0311160	1S2473D	B
L 01	4290011	3.5μH Choke Coil	A
L 02	4290011	3.5μH Choke Coil	B

4-10. F-3060 Power Supply Circuit Board for Digital Circuit (Stock No. 7503461 = G-5700) (Stock No. 7503901 = G-6700) (Stock No. 7503411 = G-7700)

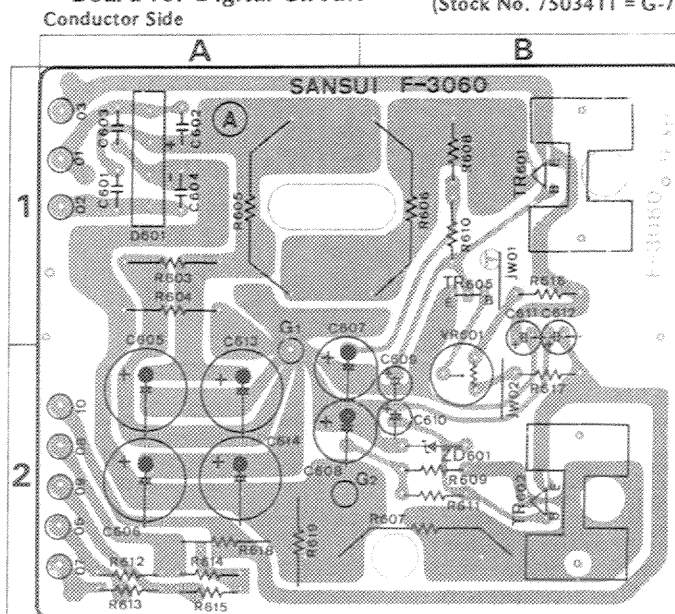

Parts List (F-3060) <G-5700/G-6700/7700>

Parts No.	Stock No.	Description	Position
*Transistor			
TR601	0308392, 3	2SD313AL E, F	1B
TR602	0303231, 2	2SB507V11AL D, E	2B
TR603	0306740, 1	2SC1845 F, E <G-5700 only>	
TR604	0306721, 2	2SA850 D, E	
TR605	0306740, 1	<G-5700/G-7700 only> 2SC1845 F, E <G-5700/G-6700 only>	1B
*Diode			
D 601	0311700	RB-152	1A
D 602	0340161	STV-3HY <G-5700 only>	
	0340170	MV-103 <G-6700/G-7700 only>	
ZD601	0316330	RD15E B	2B
C 601	0655472	4700pF 500V C.C.	1A
C 602	0655472	4700pF 500V C.C.	1A
C 603	0655472	4700pF 500V C.C.	1A
C 604	0655472	4700pF 500V C.C.	1A
R 603	0201472	4.7kΩ 1W N.J.R.	1A
R 604	0201472	4.7kΩ 1W N.J.R.	1A
R 605	0185471	470Ω 5W Ce.R.	1B
R 606	0155221	220Ω 5W Ce.R.	2B
R 607	0183391	390Ω 3W Ce.R.	
VR601	1035110	4.7kΩB, DC Voltage Adjust	2B

4-11. F-3059 Power Indicator Circuit Board (Stock No. 7598161 = G-5700)  
(Stock No. 7599141 = G-6700) (Stock No. 7597951 = G-7700)

Conductor Side

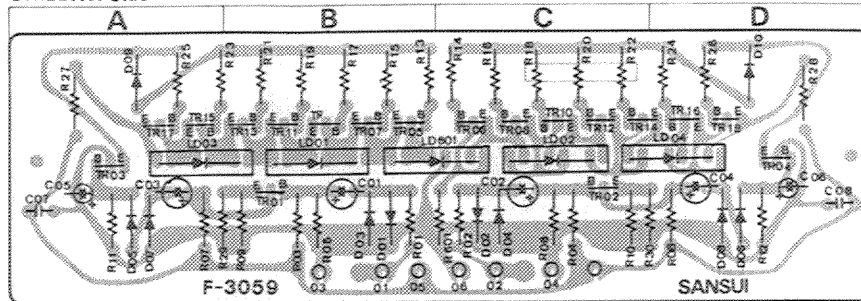

Parts List <G-5700/G-6700/G-7700>

Parts No.	Stock No.	Description	Position	Parts No.	Stock No.	Description	Position
*Transistor				*Diode			
TR01, 02	0305951, 2	2SC945 Q, P	B, C	D 01, 02	0310330	1N60	B, C
TR03, 04	0300510, 1	2SA733A P, Q	A, D	D 03, 04	0311160	1S2473D	B, C
TR05, 06	0300510, 1	2SA733A P, Q	B, C	D 05, 06	0311160	1S2473D	A, D
TR07, 08	0300510, 1	2SA733A P, Q	B, C	D 07, 08	0311160	1S2473D	A, D
TR09, 10	0300510, 1	2SA733A P, Q	B, C	D 09, 10	0311160	1S2473D	A, D
TR11, 12	0300510, 1	2SA733A P, Q	B, C				
TR13, 14	0300510, 1	2SA733A P, Q	B, C	LD01, 02	0319310	LN07202P	B, C
TR15, 16	0300510, 1	2SA733A P, Q	A, D	LD601	0319300	LN417YP	B, C
TR17, 18	0300510, 1	2SA733A P, Q	A, D				
				C 05, 06	0573338	0.33μF 35V C.C.	A, D

\* The circuit boards, F-2854, F-2860, F-3058, F-3093 & F-2981 are not supplied as the assembled, the individual parts on the circuit boards, however are provided for orders.

\* G-5700/G-6700/G-7700

4-12. F-2854 Audio Muting Circuit Board  
Conductor Side

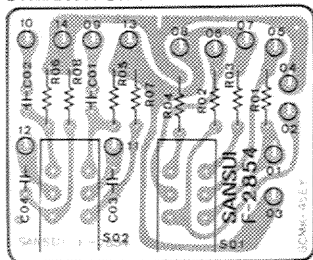

Parts List

Parts No.	Stock No.	Description
C 01, 02	0620471	470pF 50V P.C.
S 01	1131560, 1	Audio Muting & Loudness Switch

\* G-6700/G-7700

4-13. F-2860 Speaker Switch Circuit Board  
Conductor Side

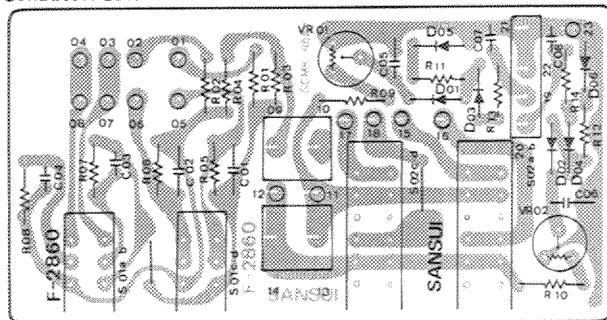

4-14. F-3058 Power Transistor Circuit Board  
Conductor Side

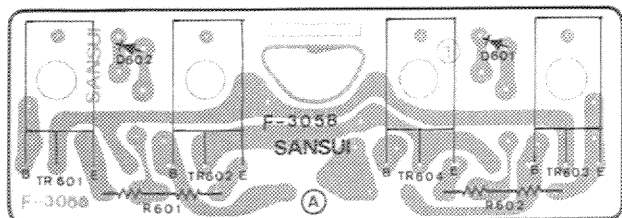

Parts List <G-6700/G-7700>

Parts No.	Stock No.	Description
*Transistor		
TR601	0306810, 1	2SC2581NLB O, Y
TR602	0301140, 1	2SA1106NLB O, Y
TR603	0306810, 1	2SC2581NLB O, Y <G 7700 only>
TR604	0301140, 1	2SA1106NLB O, Y <G 7700 only>
R 601	0159190	0.33ΩK x 2 5W Ce.R.
R 602	0159190	0.33ΩK x 2 5W Ce.R. <G 7700 only>

\* G-5700

4-15. F-2981 Power Transistor Circuit Board <L-CH>

4-16. F-3093 Power Transistor Circuit Board <R-CH>  
Conductor Side

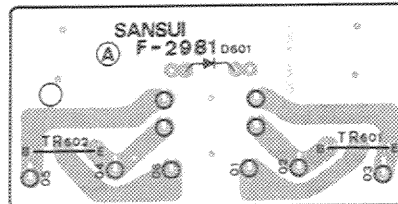

Parts List <L-CH/R-CH>

Parts No.	Stock No.	Description
*Transistor		
TR601	0306760, 1	2SC2580NLB O, Y
TR602	0301110, 1	2SA1105NLB O, Y
*Diode		
D 601	0340161, 2	STV-3H Y, G
R 601	0159190	0.33ΩK x 2 5W Ce.R.

# 5. OTHER PARTS

## ● G-5700

### 5-1. Top View

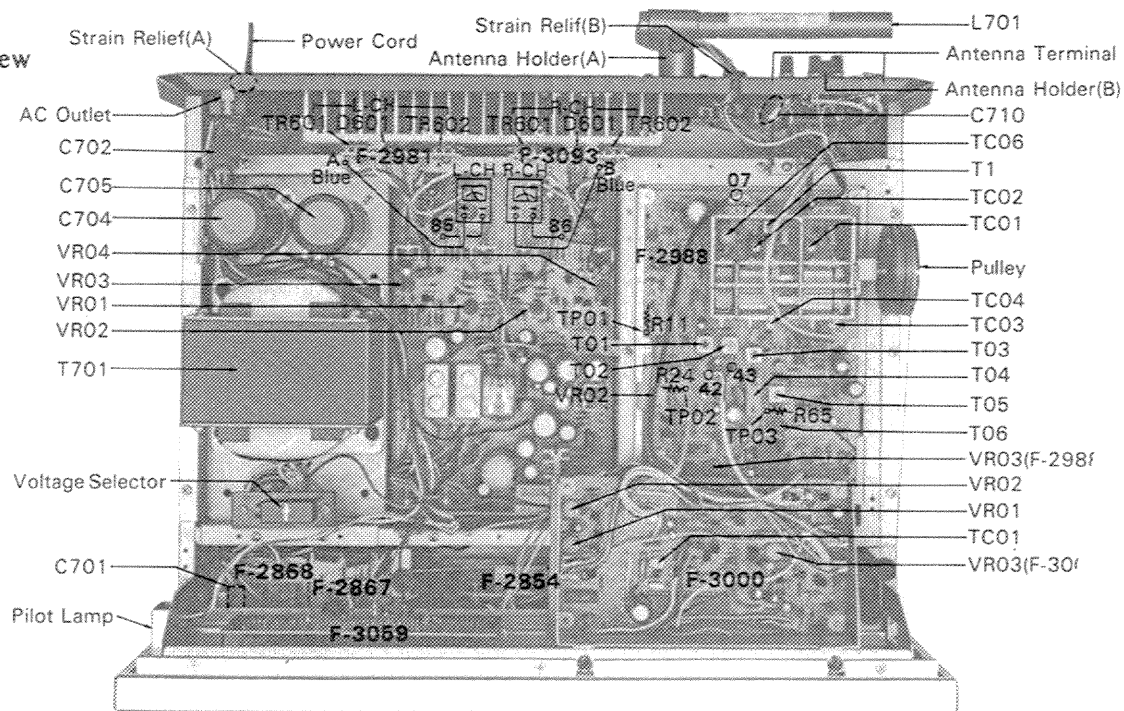

### 5-2. Bottom View

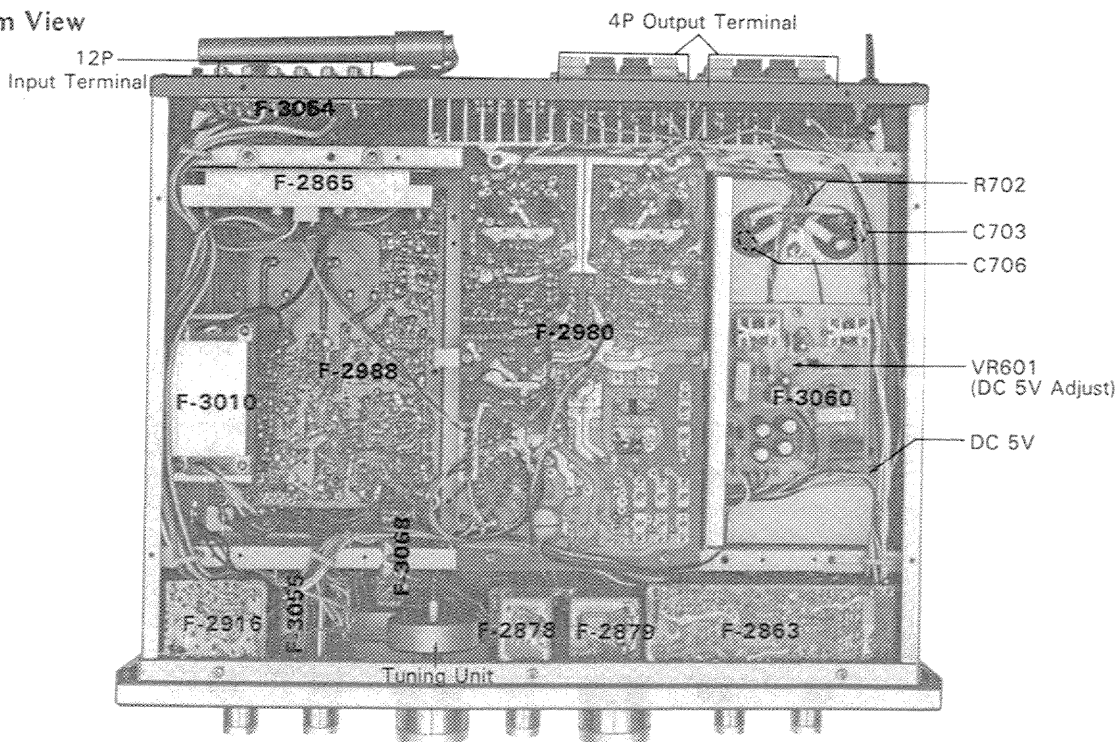

#### Parts List <Top & Bottom View>

Parts No.	Stock No.	Description	Parts No.	Stock No.	Description	Parts No.	Stock No.	Description
<b>Power Transistor</b>			C 706	0602108	0.1μF 100V M.C.	2410091		6P Voltage Selector, plug
TR601	0301110, 1	2SA1105NLB-O, Y	C 710	0620682	6800pF 50V P.C.	2410830		10P Voltage Selector, socket
TR602	0306760, 1	2SC2580NLB-O, Y	R 702	0202822	8.2kΩ 2W N.I.R.	2450070		AC Outlet
<b>Varistor</b>			L 701	4201010	Bar Antenna	6146800		Pulley
D 601	0340161, 2	STV-3H Y, G	T 701	4003100	Power Transformer	7038622		Tuning Unit
C 701	0605337	0.033μF 150V C.C.		0400710	Pilot Lamp BV 300 mA	5286450		Bar Antenna Holder (A)
C 702	0659802	0.0047μF 150V C.C.		3800470, 1	Power Cord	5286480		Bar Antenna Holder (B)
C 703	0602108	0.1μF 100V M.C.		2210310	Antenna Terminal	3910490		Strain Relief (A)
C 704	0559524	8200μF 63V E.C.		2290190	4P Output Terminal	3910600		Strain Relief (B)
C 705	0559524	8200μF 63V E.C.				2200490		12P Input Terminal

● G-6700/G-7700  
5-3. Top View

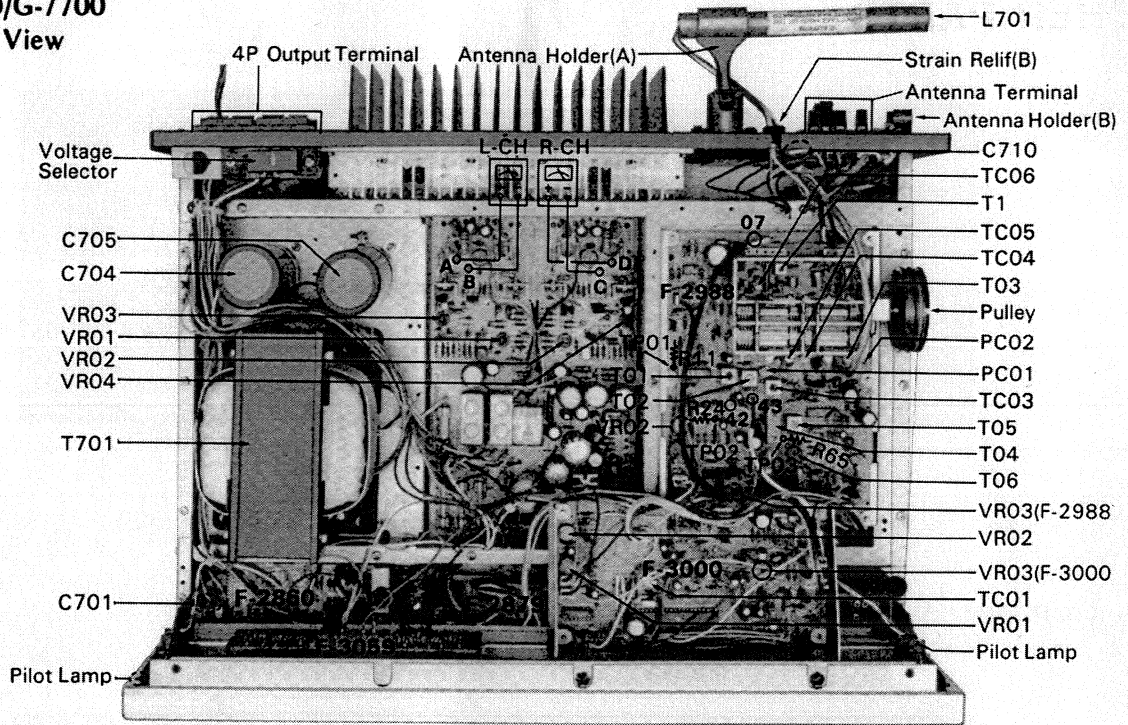

5-4. Bottom View

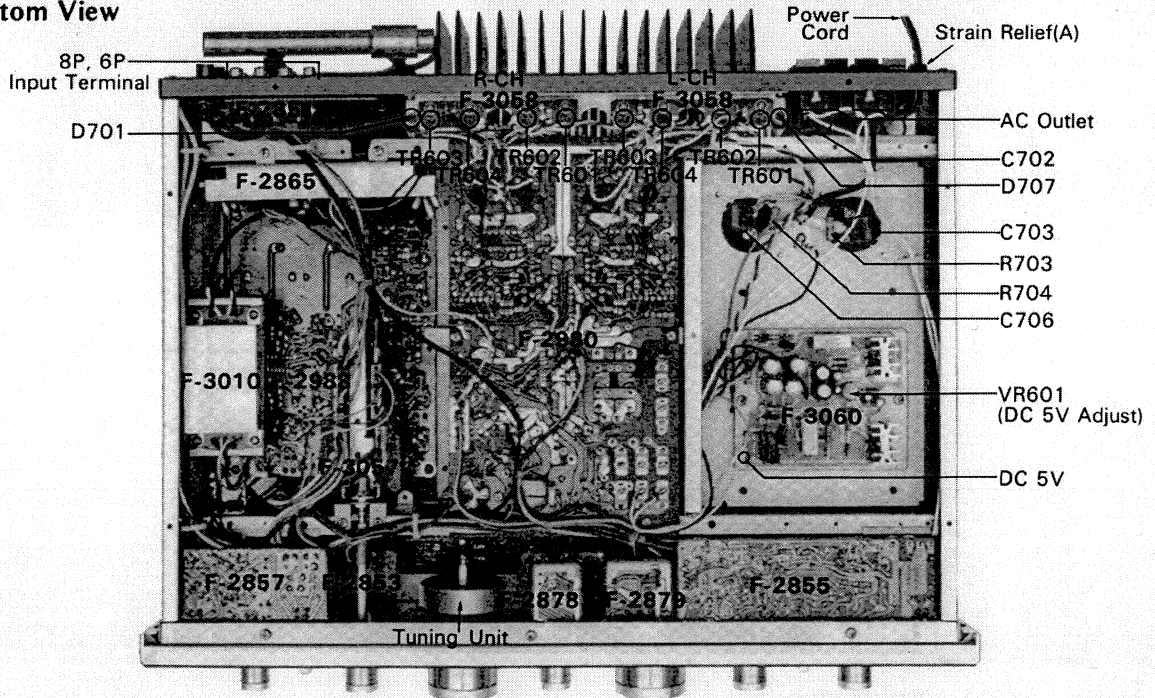

Parts List <Top & Bottom View>

Parts No.	Stock No.	Description	Parts No.	Stock No.	Description	Parts No.	Stock No.	Description
<b>Power Transistor</b>			C 704, 705	0559852	10000μF 80V E.C. <G-7700 only>	2210310		Antenna Terminal
TR 601	0306810, 1	2SC2581NLB-O, Y		0559849	10000μF 71V E.C. <G-6700 only>	2290190		4P Output Terminal
TR 602	0301140, 1	2SA1106NLB-O, Y	C 706	0602109	1μF 100V M.C.	2410091		6P Voltage Selector, plug
TR 603	0306810, 1	2SC2581NLB-O, Y	C 710	0620682	6800pF 50V P.C.	2410830		10P Voltage Selector, socket
TR 604	0301140, 1	2SA1106NLB-O, Y	R 703	0202392	3.9kΩ 2W N.I.R.	2450070		AC Outlet
<b>Varistor</b>			R 704	0202392	3.9kΩ 2W N.I.R.	6146800		Pulley
D 701	0340161, 2	STV-3H Y, G	L 701	4201010	Bar Antenna	7036623		Tuning Unit
D 702	0340161, 2	STV-3H Y, G	T 701	4003320	Power Transformer <G-6700 only>	5286450		Bar Antenna Holder (A)
C 701	0605337	0.033μF 350V M.C.		4003090	Power Transformer <G-7700 only>	5286480		Bar Antenna Holder (B)
C 702	0659802	0.0047μF 150V C.C.		0400710	Pilot Lamp 8V 300 mA	3910490		Strain Relief (A)
C 703	0602109	1μF 100V M.C.		3800470, 1	Power Cord	3910600		Strain Relief (B)
						2200480		8P Input Terminal
						2200530		6P Input Terminal

5-5. Front View <G-5700>

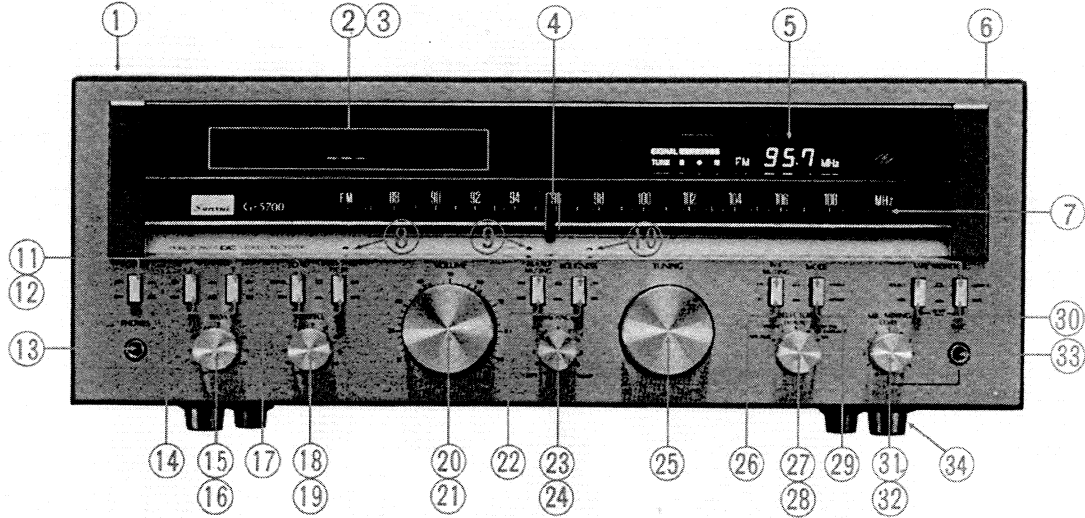

5-6. Front View <G-6700/G-7700>

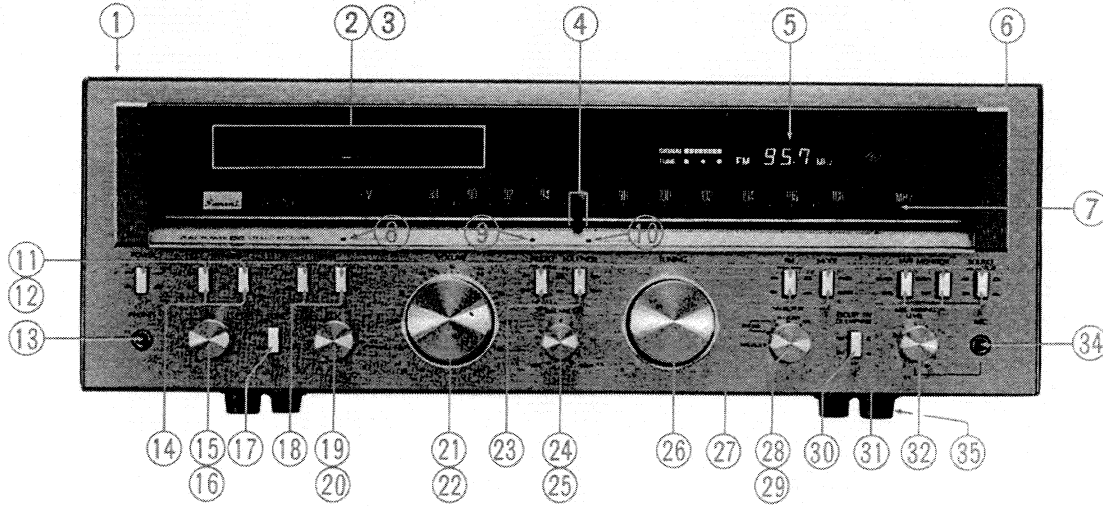

Parts List (Front View) <G-5700>

Parts No.	Stock No.	Description
1	5727162	Wood Bonnet
2	5446470	Smoked Plate
3	5426520	LED Guide Plate
4	7116101	Dial Pointer
5	0030060	Display Unit
6	7008430	Front Panel Ass'y
	5048430	Masking Plate
	5396780	Knob Guide
	5408311	Front Glass
	5457620	Dial Flame
	5517270	Masking Sheet
7	5408720	Dial Glass
8	0319050	Indicator, safety operate (green)

Parts No.	Stock No.	Description
9	0319060	Indicator, FM stereo (red)
10	0319050	Indicator, quartz locked (green)
11	5319470	Push Switch Knob
12	1131890	Power Switch
13	2430400	Head Phone Jack
14	1131580, 1	Speakers Switch
15	5319470	Knob, bass volume
16	1015360, 1	Bass Volume, 100kΩ x 2
17	1131570, 1	Tone & Subsonic Filter SW
18	5319470	Knob, treble volume
19	1015360, 1	Treble Volume, 100kΩ x 2
20	5319420	Knob, master volume
21	1011160, 1	Master Volume, 150kΩ x 2B

Parts No.	Stock No.	Description
22	1131560, 1	Audio Muting & Loudness Switch
23	5319460	Knob, balance volume
24	1015340, 1	Balance Volume, 250kΩ x 2 MN
25	5319410	Knob, tuning
26	1131560, 1	FM Muting Switch
27	5319470	Knob, selector
28	1103600, 1	Selector Switch
29	1131590, 1	MODE Switch
30	1131560, 1	FM Muting Switch
31	5319460	Knob, mic level volume
32	1090340, 1	Mic Level Volume, 20kΩA x 2
33	2430400	Mic Jack
34	5516821	Leg

Parts List (Front View) <G-6700/G-7700>

Parts No.	Stock No.	Description
1	5727172	Wood Bonnet
2	5446470	Smoked Plate
3	5426521	LED Guide Plate
4	7116101	Dial Pointer
5	0030060	Display Unit
6	7008630	Front Panel Ass'y <G-6700 only>
	7008410	Front Panel Ass'y <G-7700 only>
	5048430	Masking Plate
	5396781	Knob Guide
	5408700	Front Glass
	5457620	Dial Flame
	5517270	Masking Sheet
	5408830	Dial Glass <G-6700 only>
	5408710	Dial Glass <G-7700 only>

Parts No.	Stock No.	Description
8	0319050	Indicator, safety operate (green)
9	0319060	Indicator, FM stereo (red)
10	0319050	Indicator, quartz locked (green)
11	5319491	Push Switch Knob
12	1131890	Power Switch
13	2430400	Head Phone Jack
14	1131580, 1	Speaker Switch
15	5319470	Knob, bass volume
16	1015360, 1	Bass Volume, 100kΩ x 2
17	1131630, 1	Tone Switch
18	1131560, 1	Filters Switch
19	5319470	Knob, treble volume
20	1015360, 1	Treble Volume, 100kΩ x 2
21	5319420	Knob, master volume

Parts No.	Stock No.	Description
22	1011160, 1	Master Volume, 150kΩ x 2B
23	1131560, 1	Audio Muting & Loudness Switch
24	5319460	Knob, balance volume
25	1015340, 1	Balance Volume, 250kΩ x 2 MN
26	5319410	Knob, tuning
27	1131600, 1	FM Muting & Mode Switch
28	5319470	Knob, selector
29	1190710	Selector Switch
30	1131620, 1	Dolby FM Switch
31	1131610, 1	Tape Monitor & Source Monitor Switch
32	5319460	Knob, Mic level volume
33	1090340, 1	Mic Level Volume, 20kΩA x 2
34	2430400	Mic Jack
35	5516821	Leg

# 6. SCHEMATIC DIAGRAM 6-1. Audio Section <G-5700>

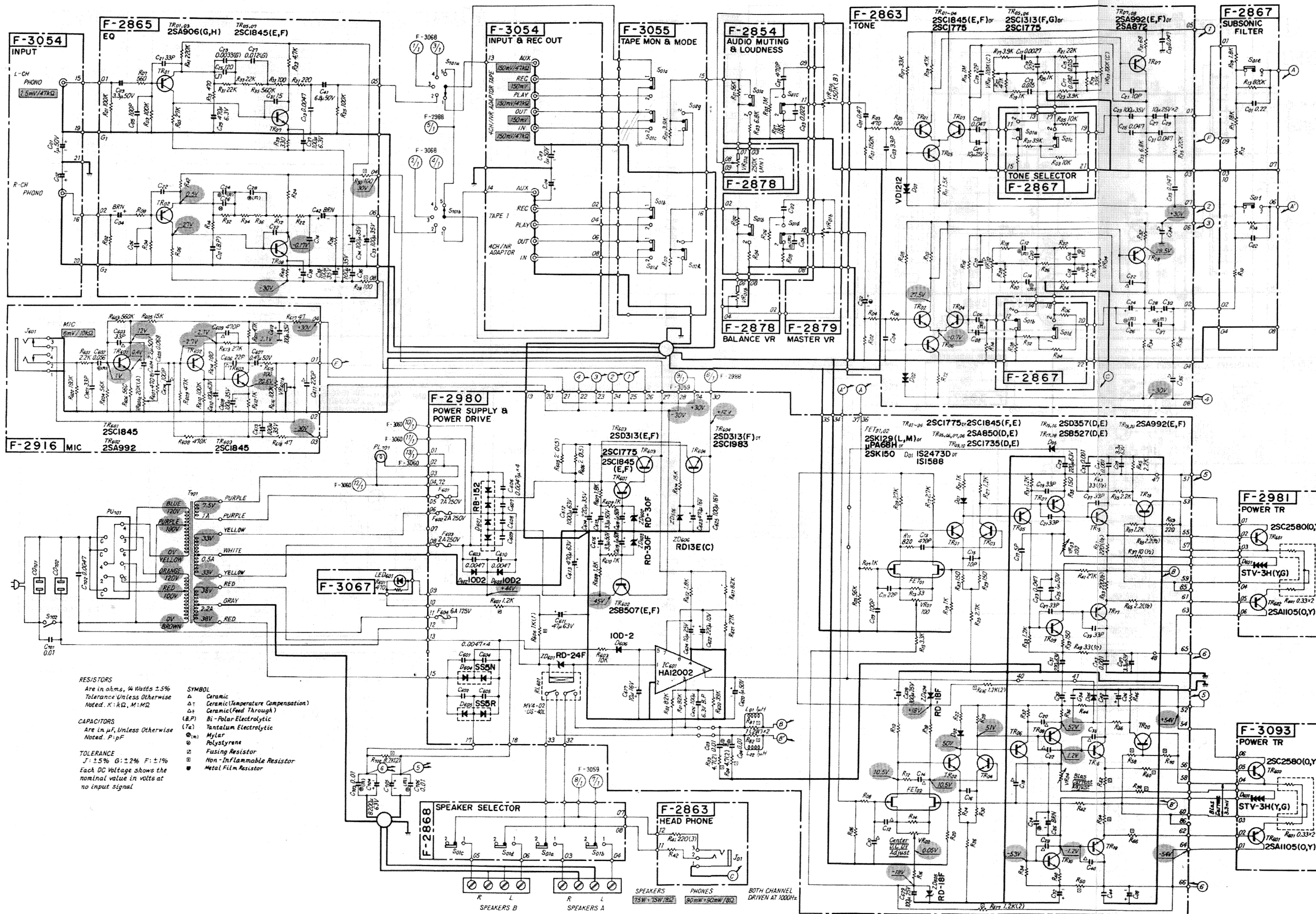

**RESISTORS**  
 Are in ohms, 4 Watts ±5%  
 Tolerance Unless Otherwise Noted. K: 1KΩ, M: 1MΩ

**SYMBOL**  
 Δ Ceramic  
 ΔT Ceramic (Temperature Compensation)  
 ⊕ Ceramic (Fed Through)  
 (L.P) Bi-Polar Electrolytic  
 (T.E) Tantalum Electrolytic  
 (M) Mylar  
 (P) Polystyrene  
 ⊕ Fusing Resistor  
 ⊕ Non-Inflammable Resistor  
 ⊕ Metal Film Resistor

**CAPACITORS**  
 Are in μF, Unless Otherwise Noted. P: pF

**TOLERANCE**  
 J: ±5% G: ±2% F: ±1%  
 Each DC Voltage shows the nominal value in volts at no input signal

1  
2  
3  
4  
5

6-2. Audio Section <G-6700>

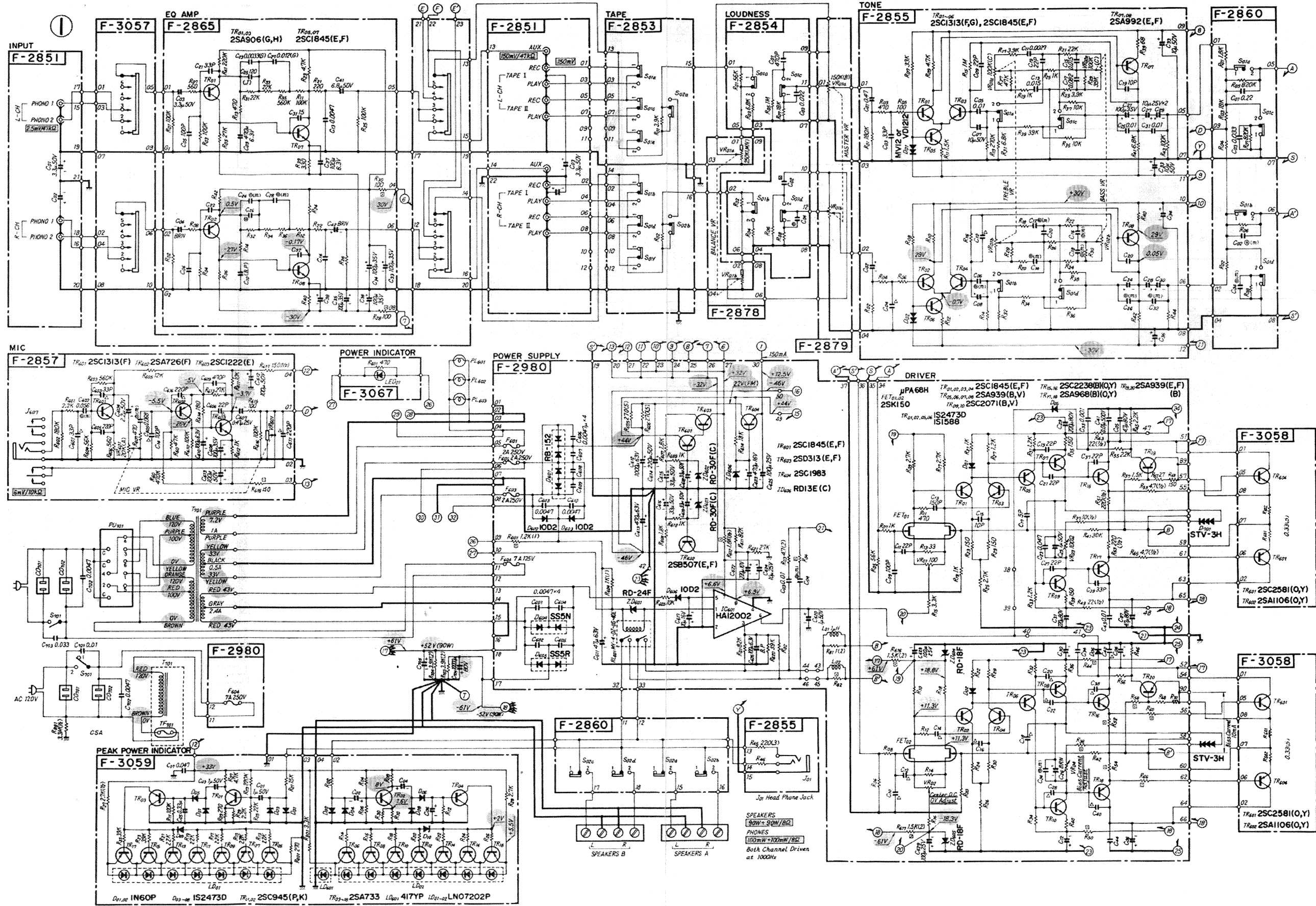



6-3. Audio Section <G-7700>

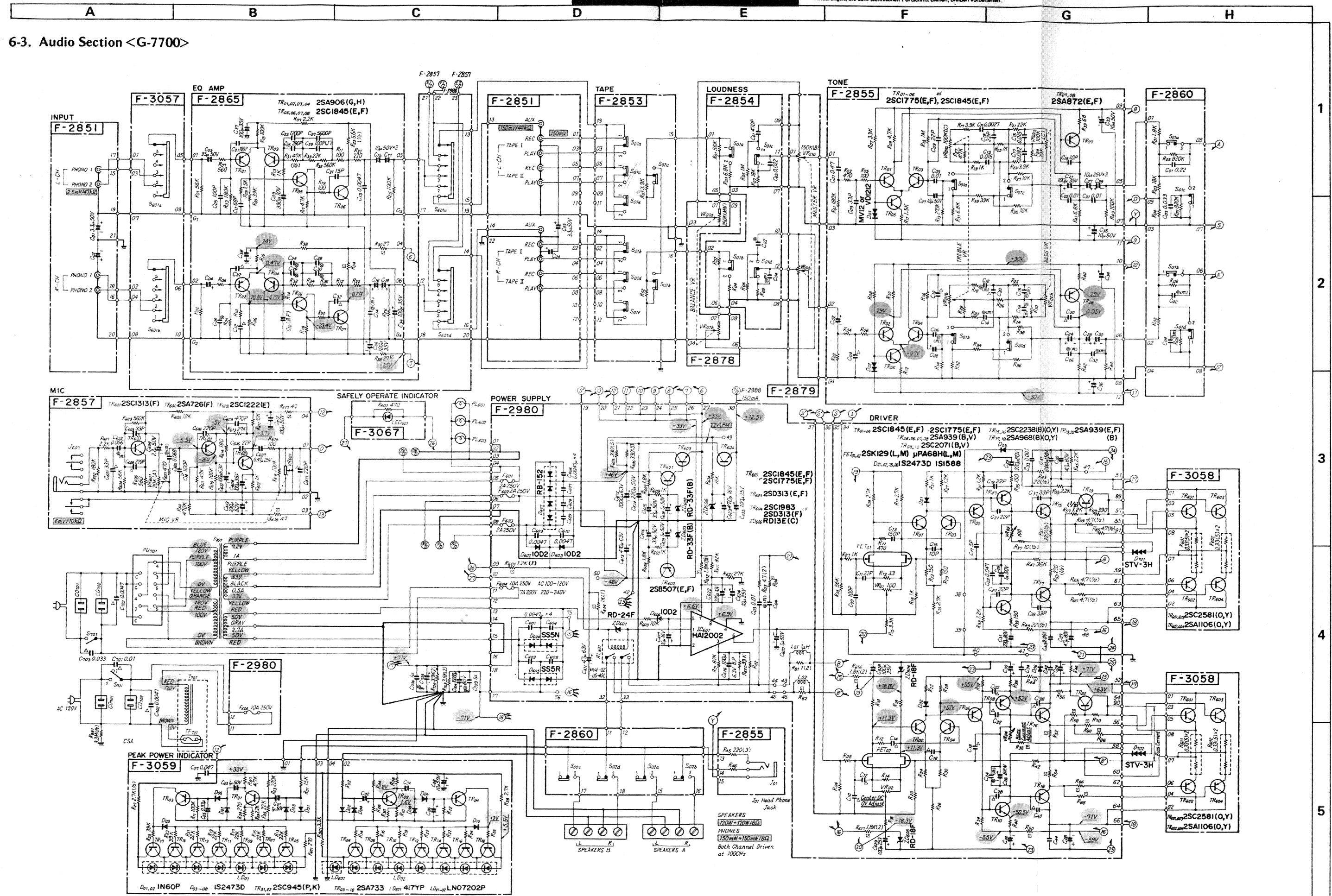

1  
2  
3  
4  
5

6-4. Tuner Section <G-5700/G-6700>

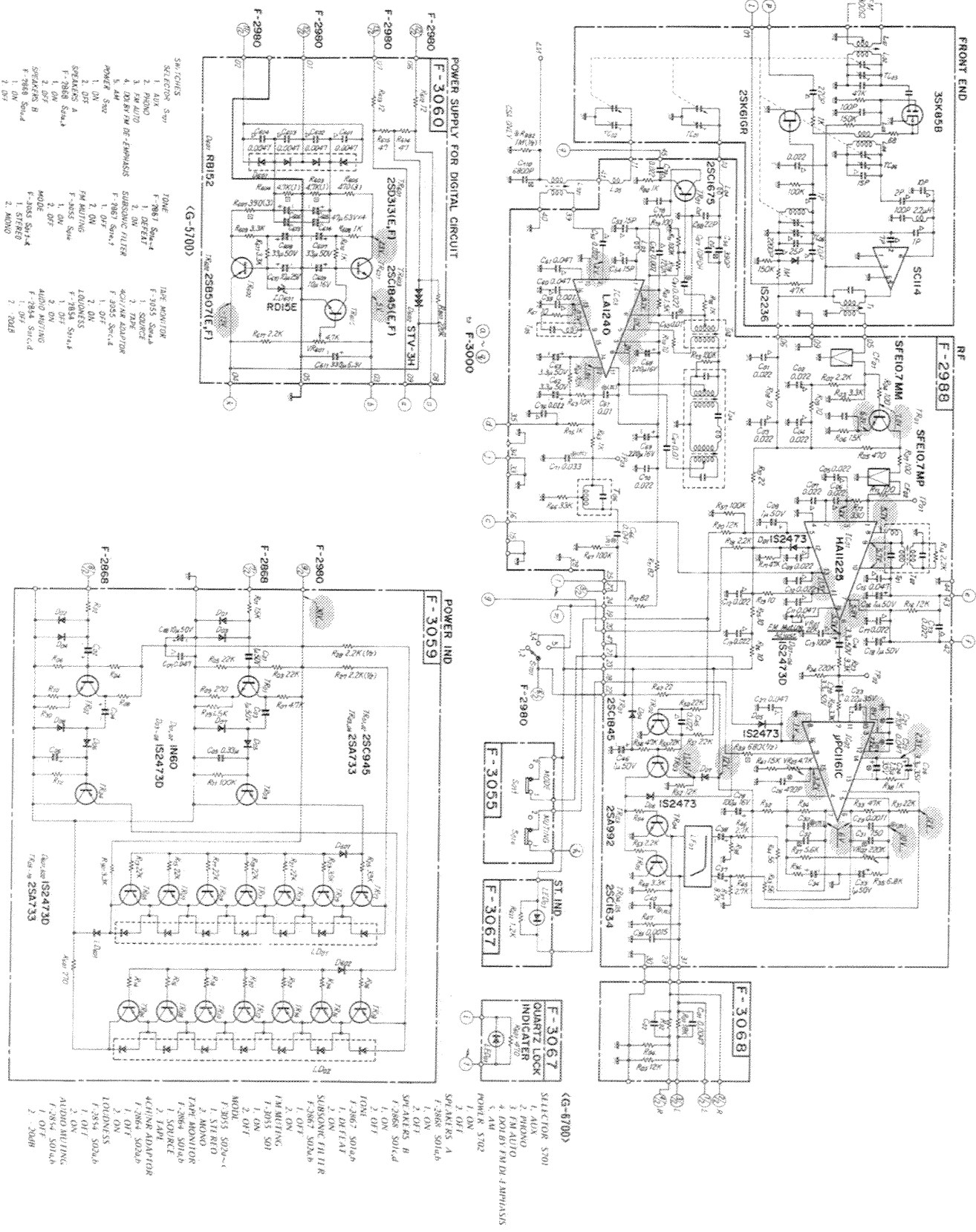

1 FRONT END  
2  
3  
4  
5



• Design and specifications subject to change without notice for improvement.  
 • La présentation et les spécifications sont susceptibles d'être modifiées sans préavis par suite d'améliorations éventuelles.  
 • Änderungen, die dem technischen Fortschritt dienen, bleiben vorbehalten.

A B C D

6-6. Digital Display Section <G-5700/G-6700/G-7700>

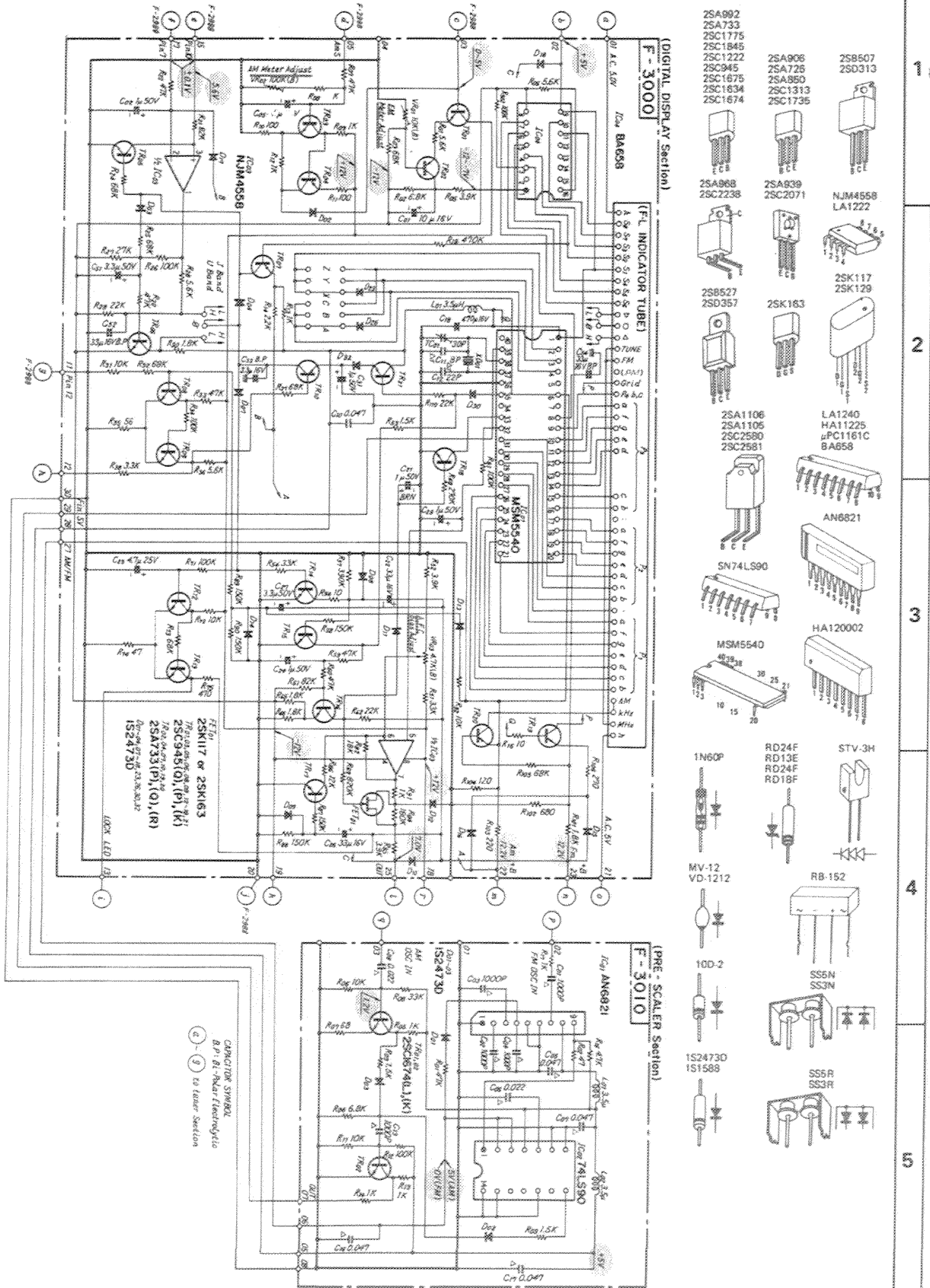

CORRECTION OF SERVICE MANUAL FOR MODELS G-5700/G-6700/G-7700

The following are corrections for the bias current adjustment in the Service Manual of the Models G-5700/G-6700/G-7700 appearing on Page 5. Please adjust the bias current by following the directions below and refer to the circuit diagram carefully.

1. G-5700

L-CH: Adjust VR-03 to get voltage as follows:  
3.3mV: between both leads of the emitter resistor for the power transistor (TR-601)

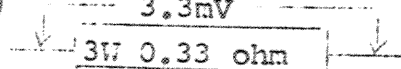

R-CH: Adjust VR-04 to get voltage as follows:  
3.3mV: between both leads of the emitter resistor for power transistor (TR-602)

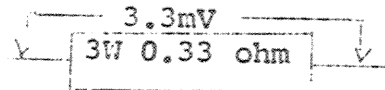

2. G-6700

L-CH: Adjust VR-03 to get voltage as follows:  
3.3mV: between both leads of the emitter resistor for power transistor (TR-604)

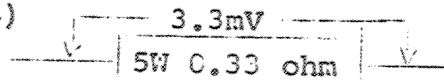

R-CH: Adjust VR-04 to get voltage as follows:  
3.3mV: between both leads of the emitter resistor for power transistor (TR-601)

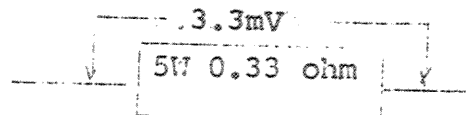

3. G-7700

L-CH: Adjust VR-03 to get voltage as follows:  
3.3mV: between both leads of the emitter resistor for power transistor (TR-601)

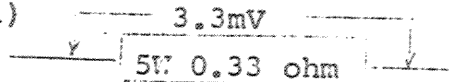

R-CH: Adjust VR-04 to get voltage as follows:  
3.3mV: between both leads of the emitter resistor for power transistor

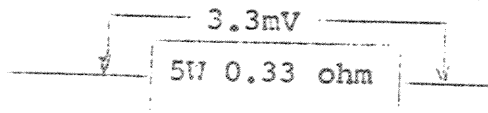

## 7. THREADING OF DIAL CORD

- If a dial cord is cut off or slips, replace it by following procedures. As this unit uses 0.5 mm  $\phi$  cord, please replace it with the same type certainly.
- The length of dial cord is approximately 200 cm (78.7 inch).

### 1. Threading of Dial Cord

Thread the dial cord in numerical order from 1 to 17 as Fig-1.

- Open the variable capacitor completely.

\* Dial Cord (0.5 mm  $\phi$ ) . . . . . (Stock No. 6036050)

### 2. Attachment of Dial Pointer

1. After installing the dial string, turn on the power switch. If the digital display is in the "FM Reception" state as shown in Fig. 8-2, turn the tuning knob until the digital display indicates 98.0 MHz. Then, fix the pointer to the dial string, after setting the pointer to the 98.0 MHz value of the scale.

2. After attaching Dial pointer, confirm Dial pointer moves from 88 MHz to 108 MHz to turn the tuning knob.

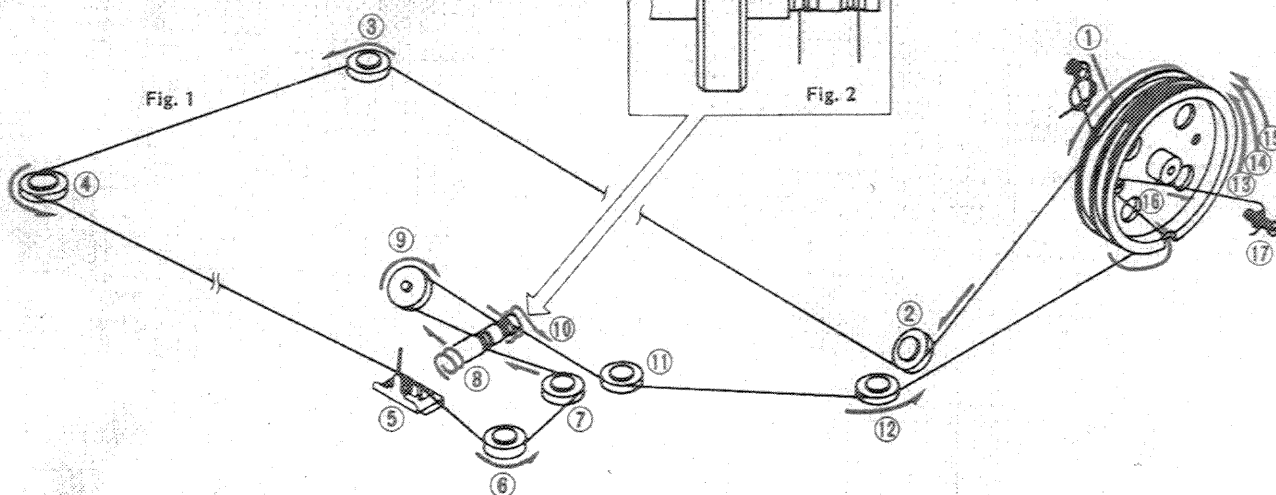

## 8. PACKING LIST

### • G-5700

Parts No.	Stock No.	Description
1	9116790	Vinyl Cover
2	9028141	Styrofoam Packing, upper
3	9028151	Styrofoam Packing, lower
4	9001951	Carton Case

### • G-6700

Parts No.	Stock No.	Description
1	9116810	Vinyl Cover
2	9028260	Styrofoam Packing, upper
3	9028270	Styrofoam Packing, lower
4	9056350	Carton Case <G-6700>
	9001931	Carton Case <G-7700>

### • G-7700

Parts No.	Stock No.	Description
1	9116810	Vinyl Cover
2	9028260	Styrofoam Packing, upper
3	9028270	Styrofoam Packing, lower
4	9001931	Carton Case <G-7700>
	9056350	Carton Case <G-6700>

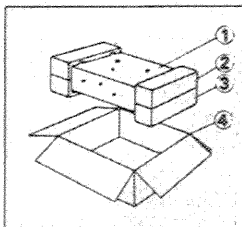

## 9. ACCESSORY PARTS LIST

### • G-5700

Stock No.	Description
9205030	Operating Instructions
9238340	Schematic Diagram
3820100	FM Antenna

### • G-6700

Stock No.	Description
9205620	Operating Instructions
9238470	Schematic Diagram
3820100	FM Antenna

### • G-7700

Stock No.	Description
9205020	Operating Instructions
9238220	Schematic Diagram
3820100	FM Antenna



SANSUI ELECTRONICS CORPORATION: 1250 Valley Brook Ave. Lyndhurst, N.J. 07071 U.S.A.  
 333 West Alondra Blvd. Gardena, California 90247 U.S.A.  
 3036 Koapaka St. Honolulu, Hawaii 96819 U.S.A.

SANSUI AUDIO EUROPE N.V.: North Trade Bldg (9th floor) Noorderlaan 133-Bus 1, 2030 Antwerp, Belgium  
 SNASUI AUDIO EUROPE S.A.: Arabella center, 6 Frankfurt AM Main, Lyoner Strasse 44-48, West Germany

SANSUI ELECTRIC COMPANY LTD.: 14-1, Izumi 2-chome, Suginamiku, Tokyo 168 Japan PHONE: (03) 323-1111/TELEX: 232-2076