

# Service Manual



## 4/2-CHANNEL RECORD/PLAYBACK 8-TRACK CARTRIDGE DECK



This model is an improved type of model RS-858US shipped previously. Because some drawings common to both models are omitted in this service manual, please refer to the service manual of model RS-858US together.

This is the Service Manual of Model RS-858DUS for PX.

## MODEL RS-858DUS

### SPECIFICATIONS

Power Source:	AC: 90~109, 110~125, 200~219, 220~250 volts, 50/60 Hz	Inputs:	4 MIC; Sensitivity 0.15 mV/applicable microphone impedance 200~600 $\Omega$
Power Consumption:	12 W	Outputs:	4 LINE; Sensitivity 45 mV/100 K $\Omega$ 4 LINE; Output level 0.8 V/load impedance 50 K $\Omega$ over 2 HEADPHONE; Output 60 mV (max.)/8 $\Omega$
Motor:	Electronic speed control motor	Program Time:	30 minutes 4-channel stereorecording with 300 feet tape
Track System:	8-track, 4-channel/2-channel stereo recording and playback	REC/PB Connection:	5 P DIN type (EIAJ)
Recording System:	AC bias, AC erase	Dimensions:	21-1/8" (W) x 4-3/4" (H) x 11 1/4" (D)
Tape Speed:	3-3/4 ips.	Weight:	20-3/4 lbs.
Fast Forward Time:	Approx. 450 seconds with 300 feet tape		
Frequency Response:	30~15,000 Hz		

These specifications are subject to change in order to accommodate improvements in design.

**PANASONIC TOKYO**  
**DIVISION OF MATSUSHITA ELECTRIC INDUSTRIAL CO., LTD**

8-2, 4-chome, Shiba, Minato-ku, 180 Japan  
Tel. (453) 3111 (Ext. 611, 612), 0421  
Cable Address, "NATIONAL TOKKI" TOKYO

# LOCATION OF PARTS

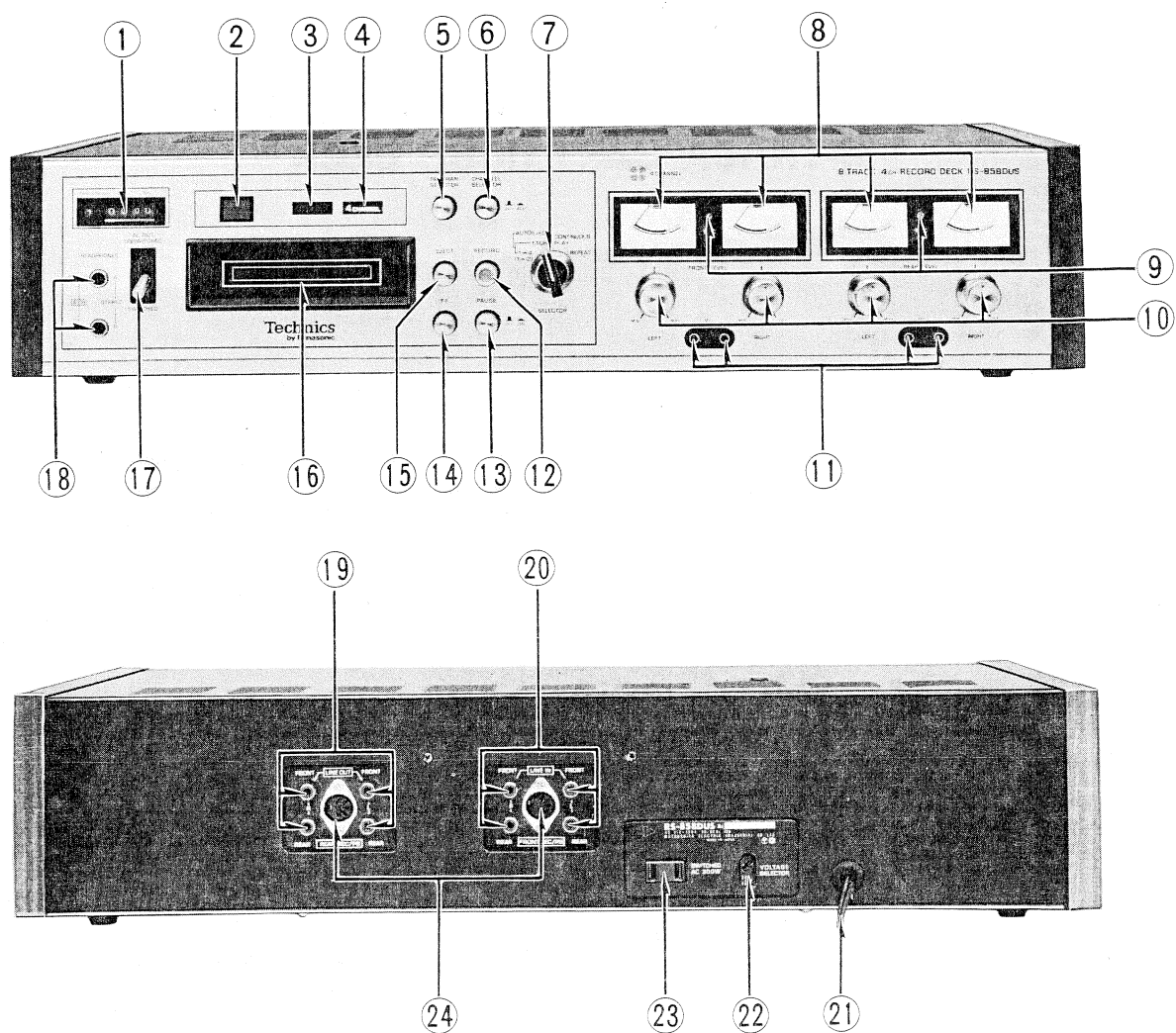

Fig. 1

- |                             |                                |
|-----------------------------|--------------------------------|
| ① Time counter              | ⑬ Pause button                 |
| ② Program indication lamp   | ⑭ Fast forward button          |
| ③ 2-channel indication lamp | ⑮ Ejection button              |
| ④ 4-channel indication lamp | ⑯ Tape slot                    |
| ⑤ Program selection button  | ⑰ AC power socket selector     |
| ⑥ 2/4-channel selector      | ⑱ Front/rear headphone jacks   |
| ⑦ Operation selector        | ⑲ Line output jacks            |
| ⑧ Level meters              | ⑳ Line input jack              |
| ⑨ Recording indicators      | ㉑ Power cord                   |
| ⑩ Volume controls           | ㉒ Voltage selector             |
| ⑪ Microphone jacks          | ㉓ AC power socket              |
| ⑫ Record button             | ㉔ Recording/playback connector |

# STANDARD VALUE TO TEST

ITEM	VALUE	PARTS TO BE ADJUSTED	REMARKS
1	Pressure of Pressure Roller.	2,000±200 gr	Lock Lever Spring. —
2	Head Arm Attraction.	180±20 gr	Head Pressure Spring. —
3	Plunger Load. (Program Selector)	1,200±200 gr	— —
4	Head Azimuth Adjustment.	Maximum	Head Azimuth Adjustment Screw. Use test tape (VTT-801)...at R-CH.
5	Head Height Adjustment.	Minimum	Head Height Adjustment Screw. Use test tape (VTT-801)...at L-CH.
6	Crosstalk Adjustment.	more than 50 dB	Repeat steps 4 and 5. Use test tape (VTT-804, VTT-802).
7	Playback Gain.	0.8 V	VR1(CH1), VR1'(CH3), VR2(CH2), VR2'(CH4). Use test tape (8-FC).
8	Bias Oscillation Frequency.	35±5 kHz	T3 —
9	Erase Current.	0.18±0.01 V	VR7 VTVM to both ends of R71 (10 Ω).
10	Bias Current.	55±5 mV	L1(CH1), L1'(CH3), L2(CH2), L2'(CH4). VTVM to both ends of $\left. \begin{array}{l} R5 (CH1) \\ R6 (CH2) \\ R5' (CH3) \\ R6' (CH4) \end{array} \right\}$
11	Standard Recording Level.	1 kHz MIC: -76±4 dB LINE IN: -27±4 dB DIN: -36±4 dB	— To obtain 4 mV across R5, 6, 5', 6'. Stop the bias oscillation by unsoldering the wire (A) as shown on printed circuit Board (page 6).
12	Recording Level Indicator	0 VU on level indicator	VR5(CH1), VR5'(CH3), VR6(CH2), VR6'(CH4). The same as above.
13	Overall Frequency Response.	1 kHz: 0 dB 100 Hz: 0±6 dB 9 kHz: -1 <sup>+4</sup> / <sub>-6</sub> dB	— Record with level lower by 10 dB than standard recording level.
14	Overall Signal-to-Noise Ratio.	more than 36 dB	— At 0.65 V of playback output.
15	Overall Distortion.	less than 5%	— The same as above.

# CABINET PARTS

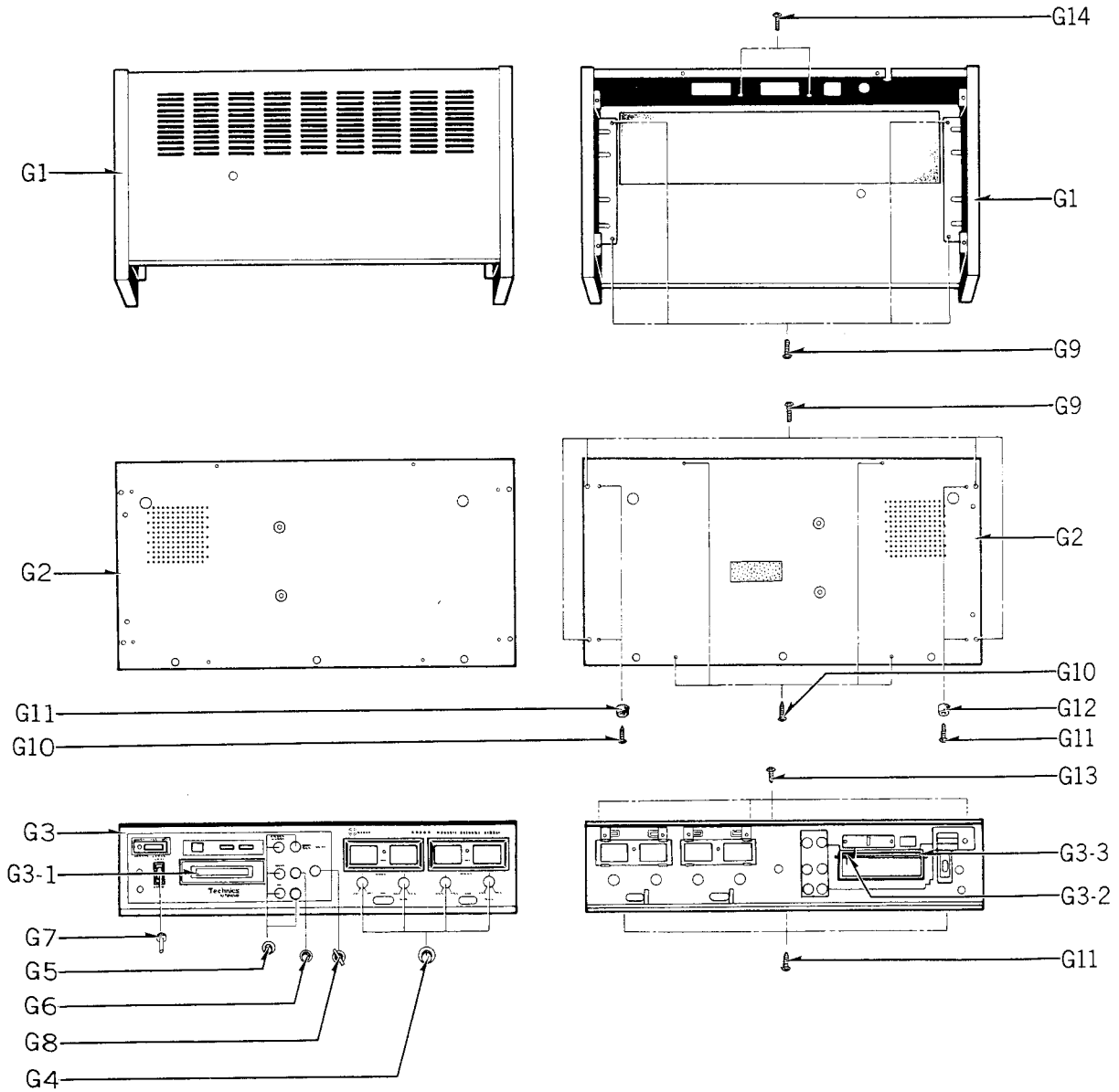



## STANDARD VALUE TO TEST

	ITEM	VALUE	PARTS TO BE ADJUSTED	REMARKS
1	Pressure of Pressure Roller.	$2,000 \pm 200$ gr	Lock Lever Spring.	—
2	Head Arm Attraction.	$180 \pm 20$ gr	Head Pressure Spring.	—
3	Plunger Load. (Program Selector)	$1,200 \pm 200$ gr	—	—
4	Head Azimuth Adjustment.	Maximum	Head Azimuth Adjustment Screw.	Use test tape (VTT-801)...at R-CH.
5	Head Height Adjustment.	Minimum	Head Height Adjustment Screw.	Use test tape (VTT-801)...at L-CH.
6	Crosstalk Adjustment.	more than 50 dB	Repeat steps 4 and 5.	Use test tape (VTT-804, VTT-802).
7	Playback Gain.	0.8 V	VR1(CH1), VR1'(CH3), VR2(CH2), VR2'(CH4).	Use test tape (8-FC).
8	Bias Oscillation Frequency.	$35 \pm 5$ kHz	T3	—
9	Erase Current.	$0.18 \pm 0.01$ V	VR7	VTVM to both ends of R71 (10 $\Omega$ ).
10	Bias Current.	$55 \pm 5$ mV	L1(CH1), L1'(CH3), L2(CH2), L2'(CH4).	VTVM to both ends of $\left. \begin{array}{l} R5 (CH1) \\ R6 (CH2) \\ R5' (CH3) \\ R6' (CH4) \end{array} \right\}$
11	Standard Recording Level.	1 kHz MIC: $-76 \pm 4$ dB LINE IN: $-27 \pm 4$ dB DIN: $-36 \pm 4$ dB	—	To obtain 4 mV across R5, 6.5', 6'. Stop the bias oscillation by unsoldering the wire (A) as shown on printed circuit Board (page 6).
12	Recording Level Indicator	0 VU on level indicator	VR5(CH1), VR5'(CH3), VR6(CH2), VR6'(CH4).	The same as above.
13	Overall Frequency Response.	1 kHz: 0 dB 100 Hz: $0 \pm 6$ dB 9 kHz: $-1 \begin{smallmatrix} +4 \\ -6 \end{smallmatrix}$ dB	—	Record with level lower by 10 dB than standard recording level.
14	Overall Signal-to-Noise Ratio.	more than 36 dB	—	At 0.65 V of playback output.
15	Overall Distortion.	less than 5%	—	The same as above.

# CABINET PARTS

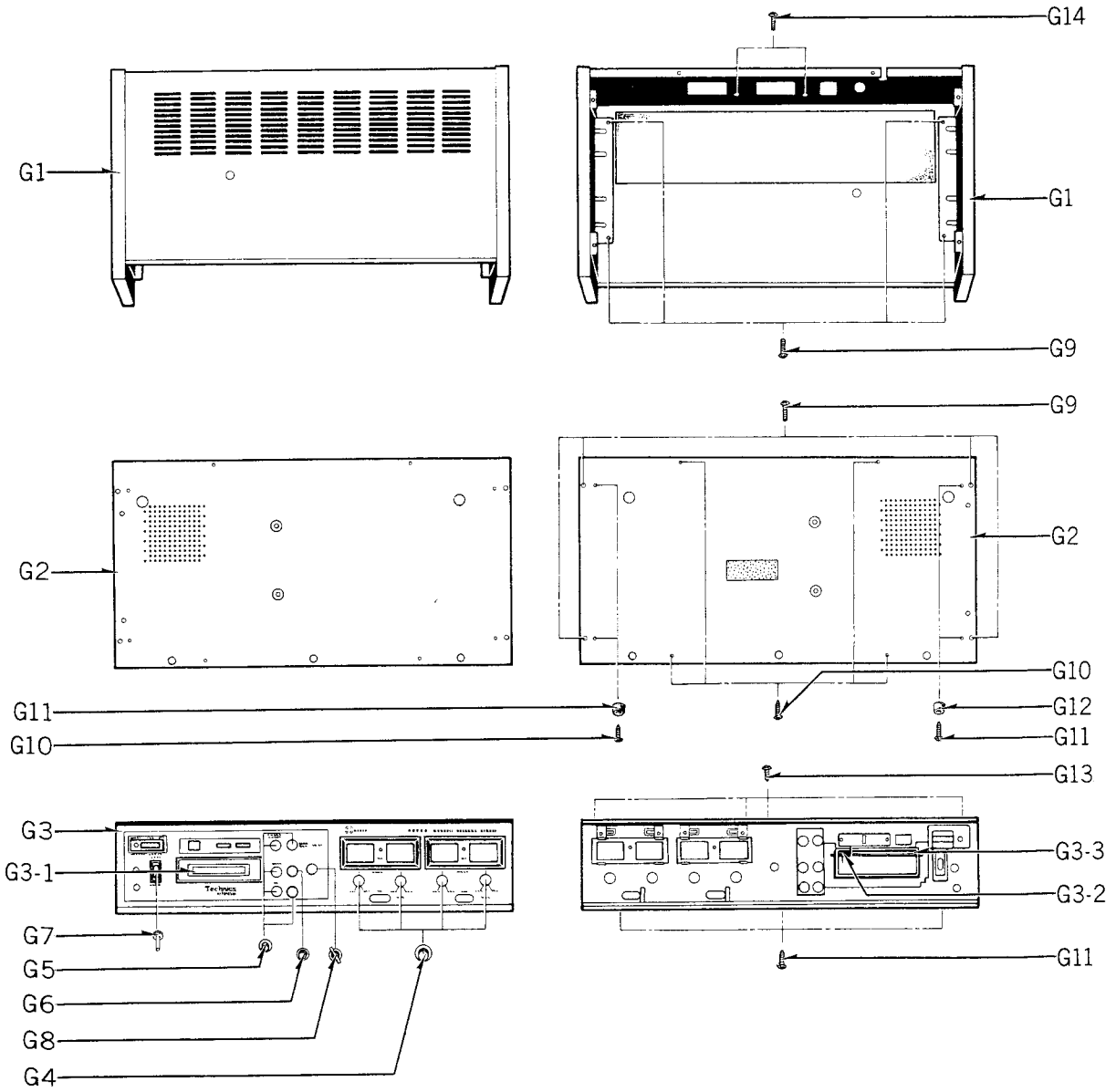

# EXPLODED VIEWS

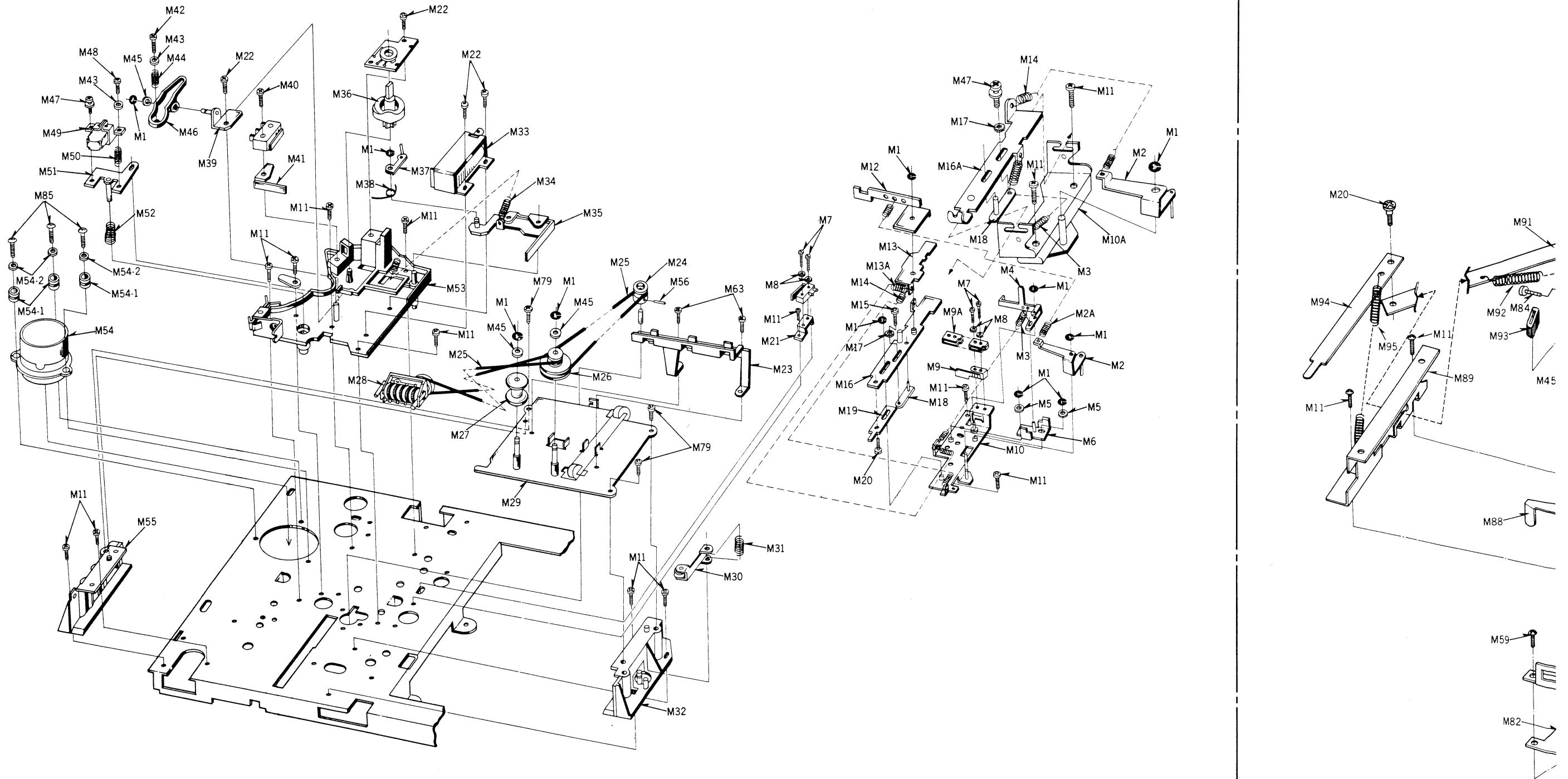

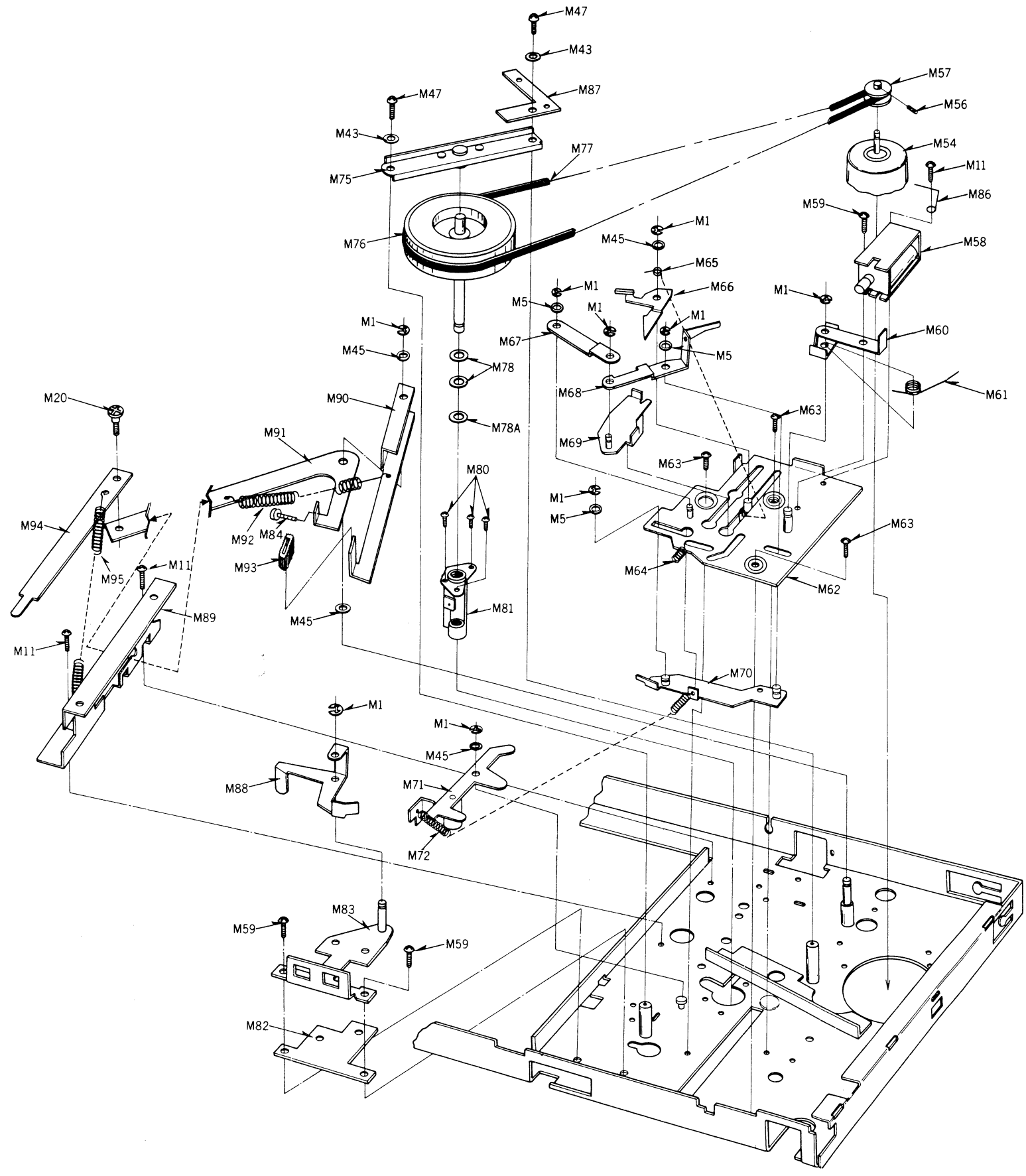
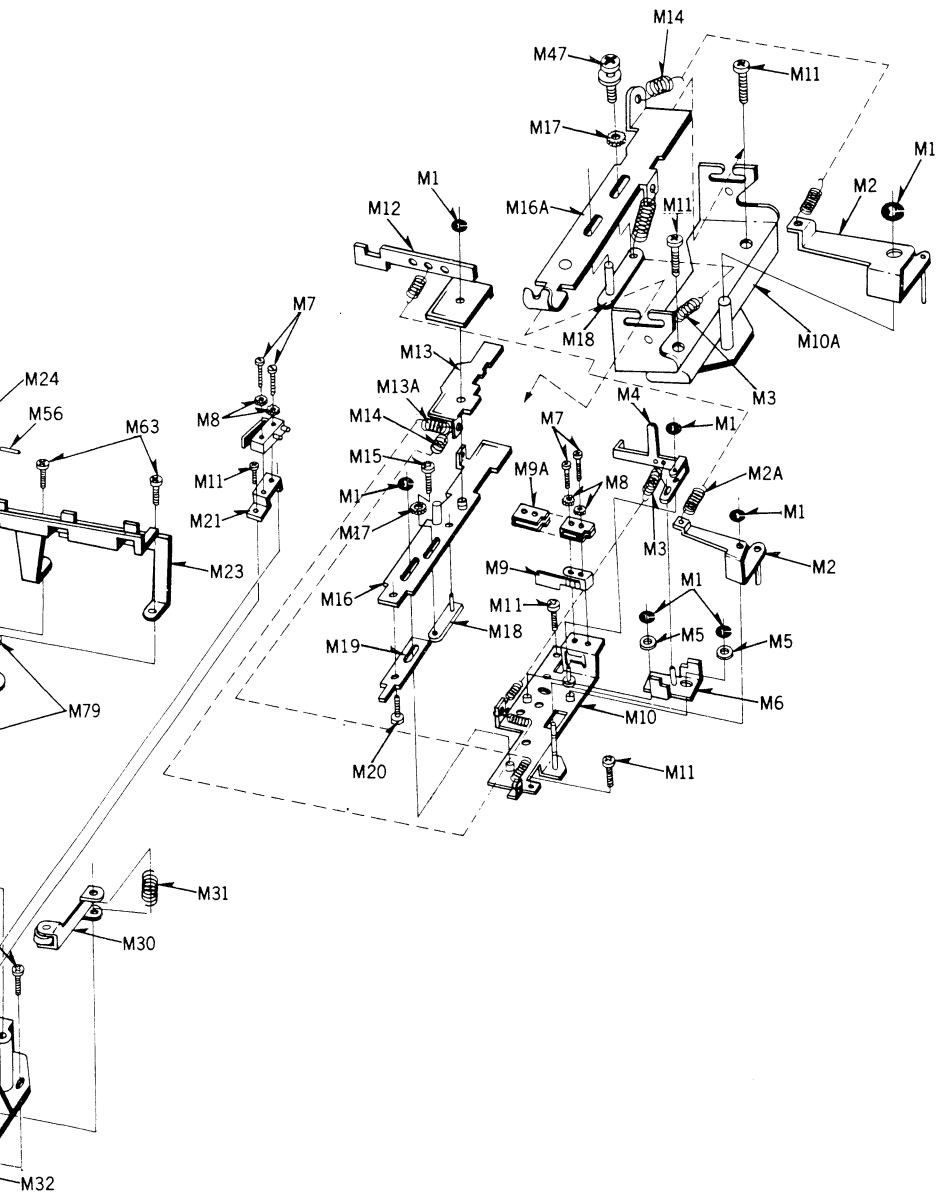

# SCHEMATIC DIAGRAM MODEL RS-858DUS

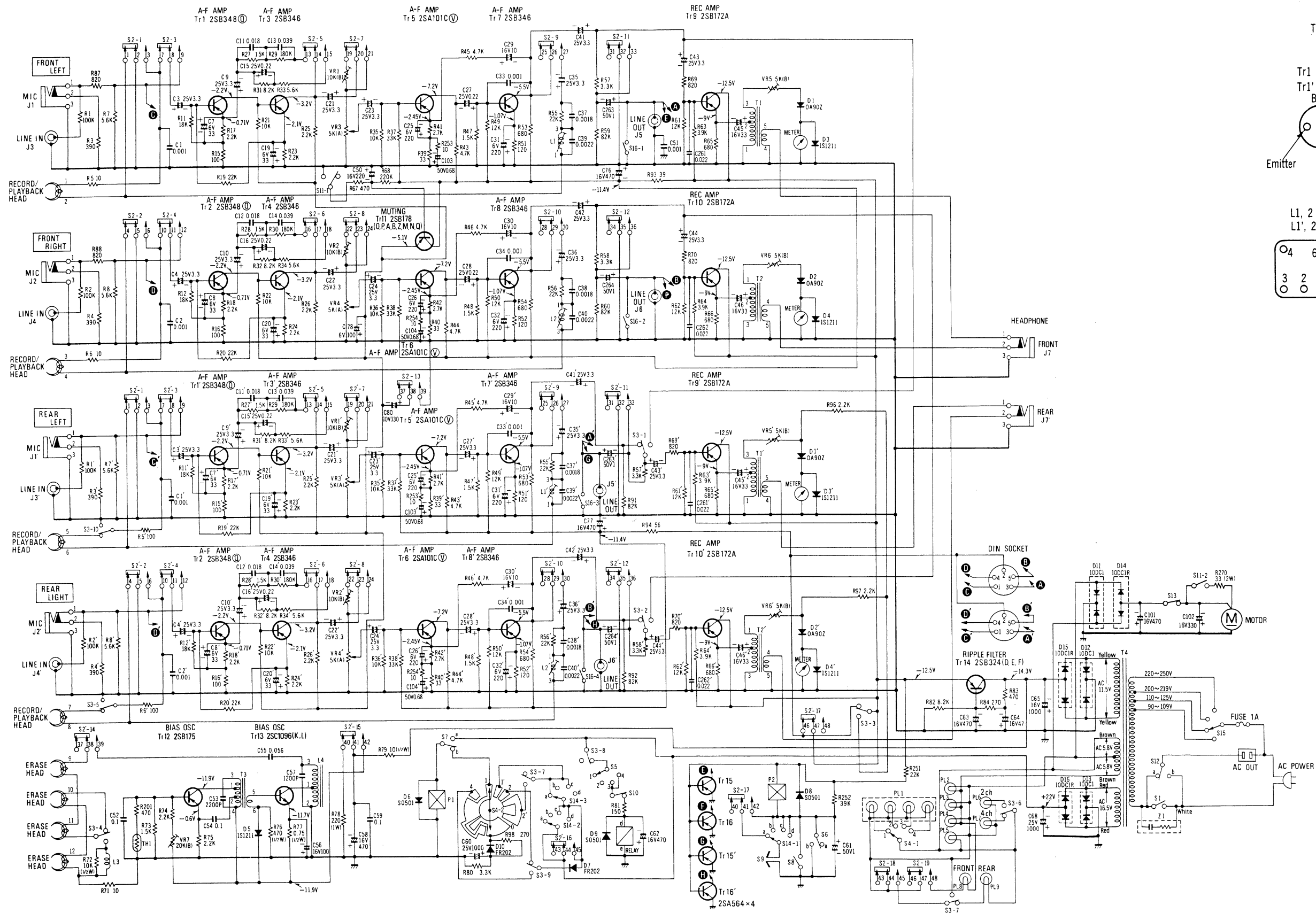

TRANSISTOR, TRANSFORMER, & COIL

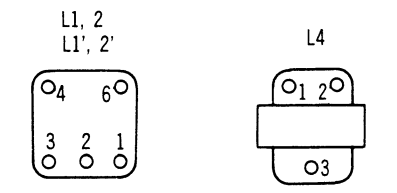
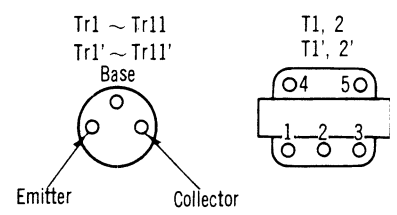

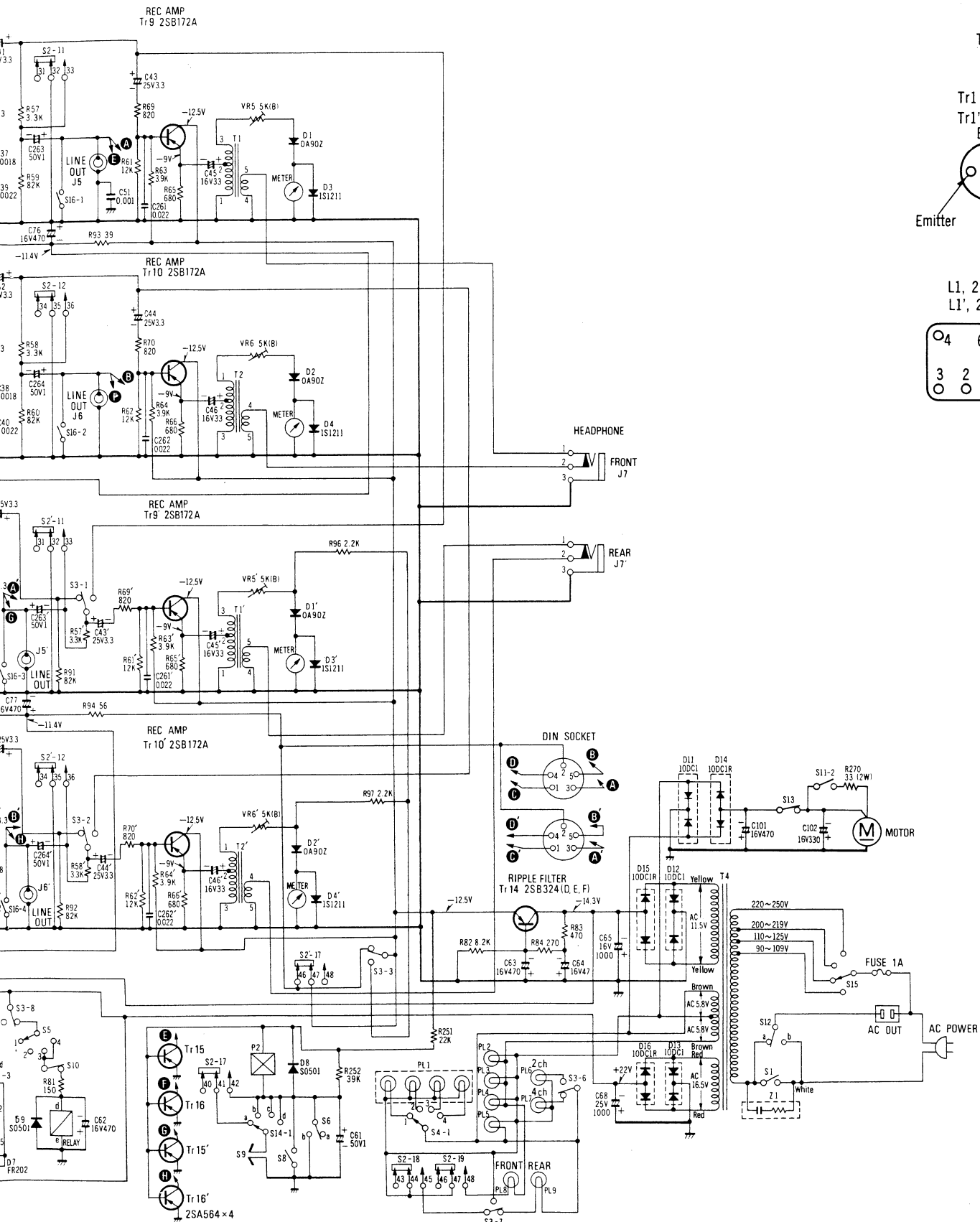

TRANSISTOR, TRANSFORMER, & COIL TERMINATION

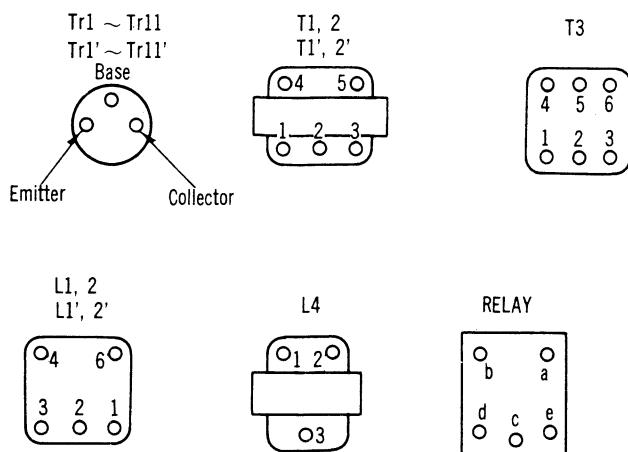

HEAD TERMINATION AND WIRING (REAR VIEW)

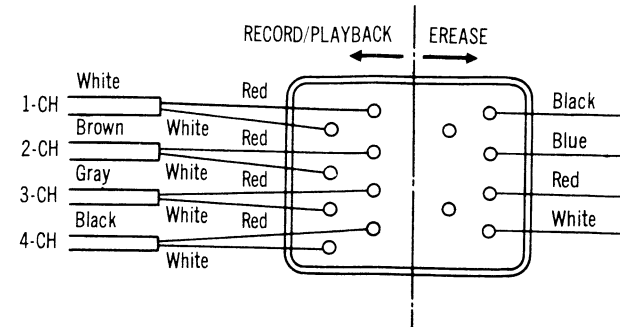

NOTE:

- S1 ..... Power ON/OFF switch (ON when record button is pressed or cartridge is put in).
- S2-1~S2-19 }  
S2'-1~S2'-17 } ... Record/playback select switch (shown in playback position).
- S3-1~S3-10 ..... 4/2-channel select switch (shown in 4-CH position).
- S4-1, S4-2 ..... Program indicator switch.
- S5 ..... Plunger switch (ON with program 3 or 4).
- S6 ..... Relay switch (a→b when relay is energized).
- S7 ..... Manual eject switch (a: eject position).
- S8 ..... Program select switch.
- S9 ..... Sensing switch.
- S10 ..... Relay function switch.
- S11-1, S11-2 ... Fast forward switch.
- S12 ..... AC OUT switch.
- S13 ..... Pause switch.
- S14-1~S14-3 ... Operation select switch.  
(a: REPEAT, b: CONTINUOUS PLAY, c: AUTOEJECT EACH, d: AUTOEJECT 1→4 (1→2)).
- S15 ..... AC Voltage select switch.
- S16-1~S16-4 ... Cartridge switch (close when cartridge is put in).
- VR1, 2, 1', 2' ..... Playback level adjustment VR.
- VR3, 4, 3', 4' ..... Volume control.
- VR5, 6, 5', 6' ..... Level indicator adjustment VR.
- VR7 ..... Erase current adjustment VR.
- PL1 ..... Program indicator lamp.
- PL2, 3, 4, 5 ..... Pilot lamp for level meter.
- PL6, 7 ..... 4/2-channel indicator.
- PL8, 9 ..... Record indicator.
- Resistor values are in ohms ( $\Omega$ ), 1/4, watt unless specified otherwise. K=1,000 $\Omega$ .
- Capacitor values are in microfarads ( $\mu F$ ) unless specified otherwise. P=Pico-farads.
- All measurements are under no signal conditions with volume at minimum position. Use VTVM for DC voltage measurements.

# CIRCUIT BOARD

## MAIN CIRCUIT BOARD

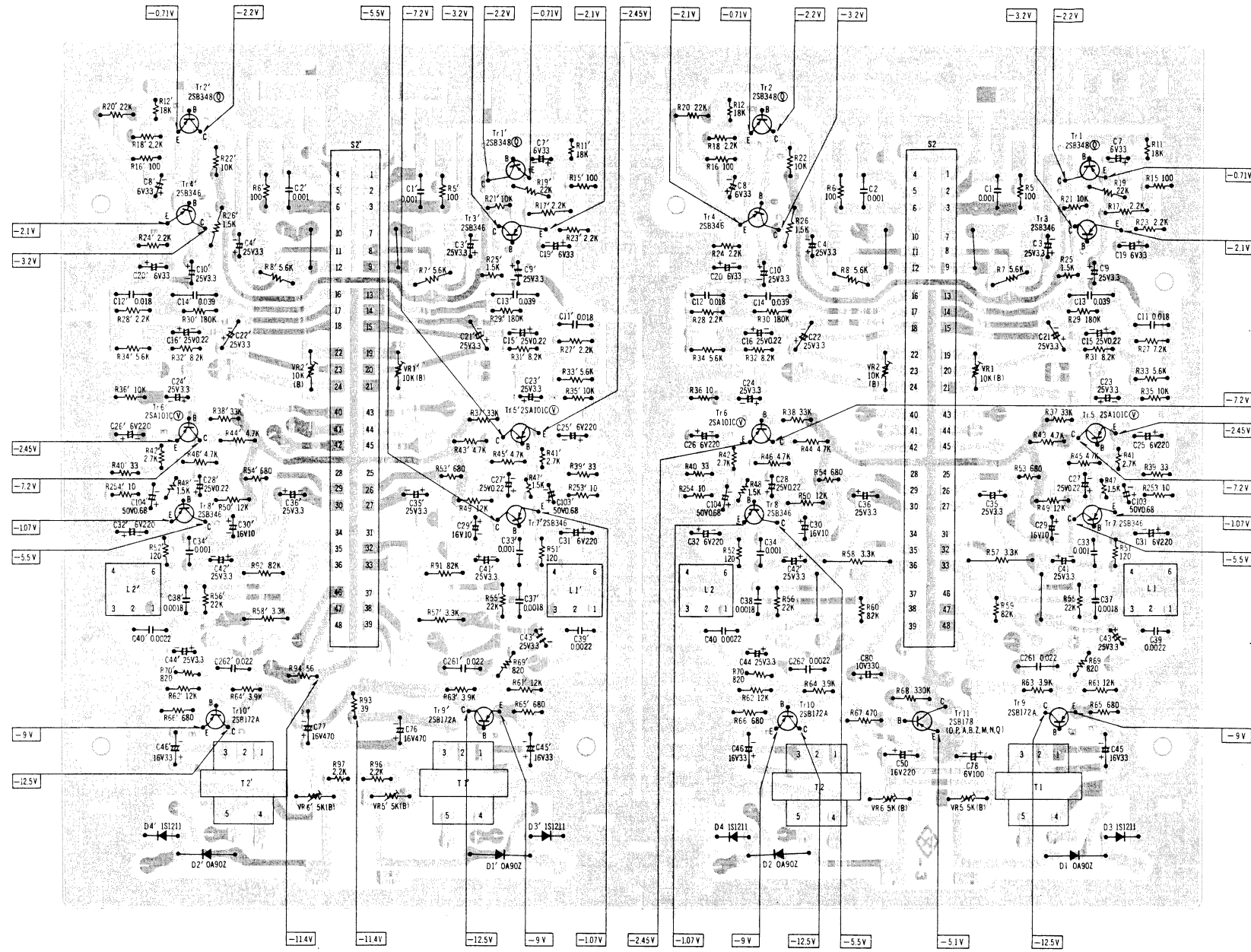

## POWER CIRCUIT BOARD

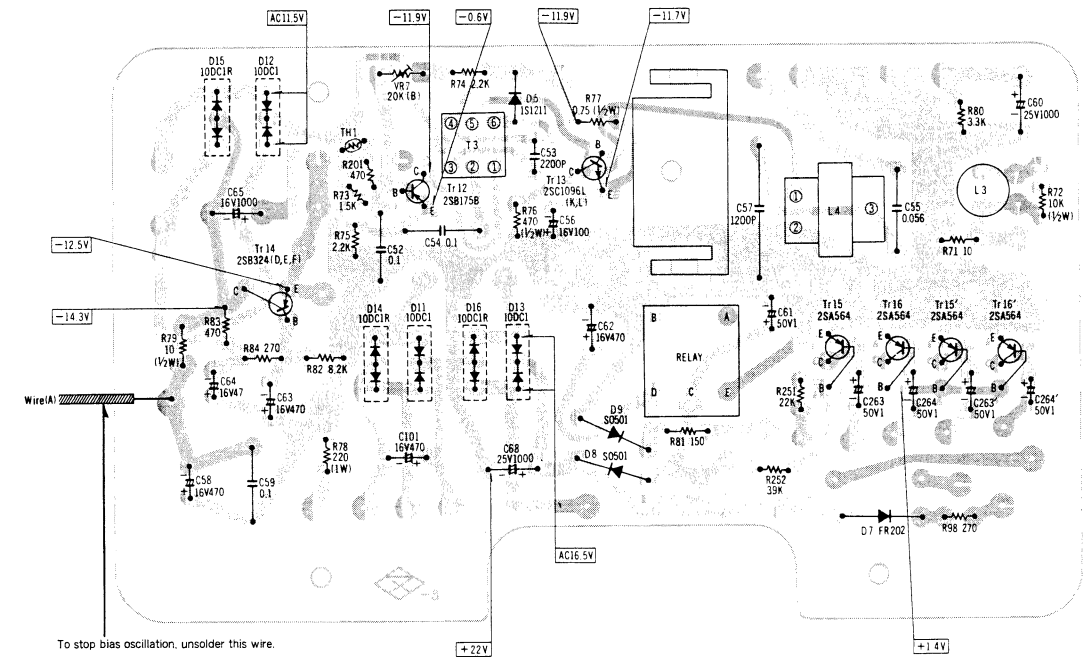

**NOTE:**

The circuit shown in red on the conductor – B circuit.  
Values indicated in    are DC voltages between the chassis and electrical parts.



# WIRING CONNECTION DIAGRAM MODEL RS-858DUS

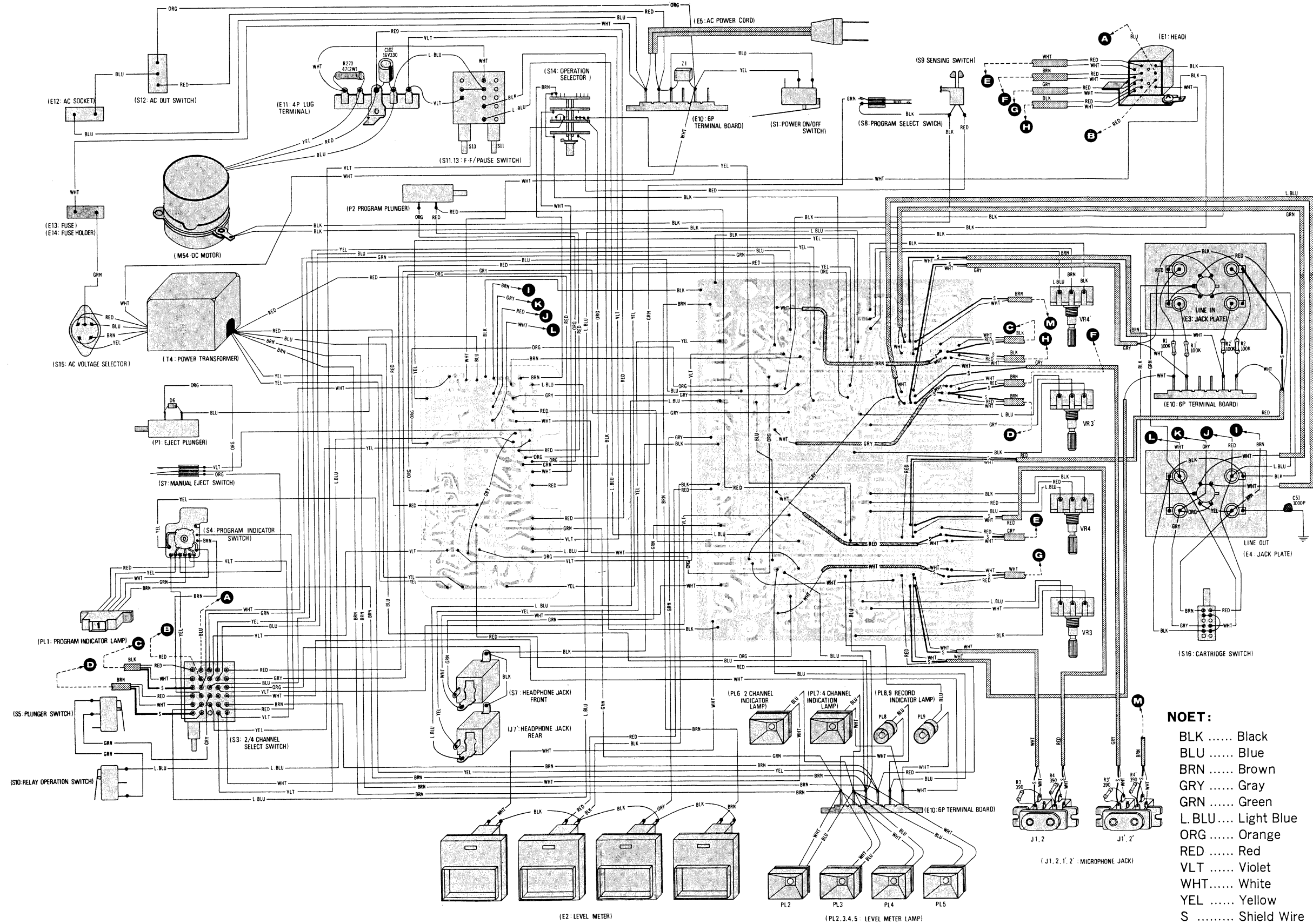

- NOET:**
- BLK ..... Black
  - BLU ..... Blue
  - BRN ..... Brown
  - GRY ..... Gray
  - GRN ..... Green
  - L. BLU.... Light Blue
  - ORG ..... Orange
  - RED ..... Red
  - VLT ..... Violet
  - WHT ..... White
  - YEL ..... Yellow
  - S ..... Shield Wire



# SCHEMATIC DIAGRAM MODEL RS-858US

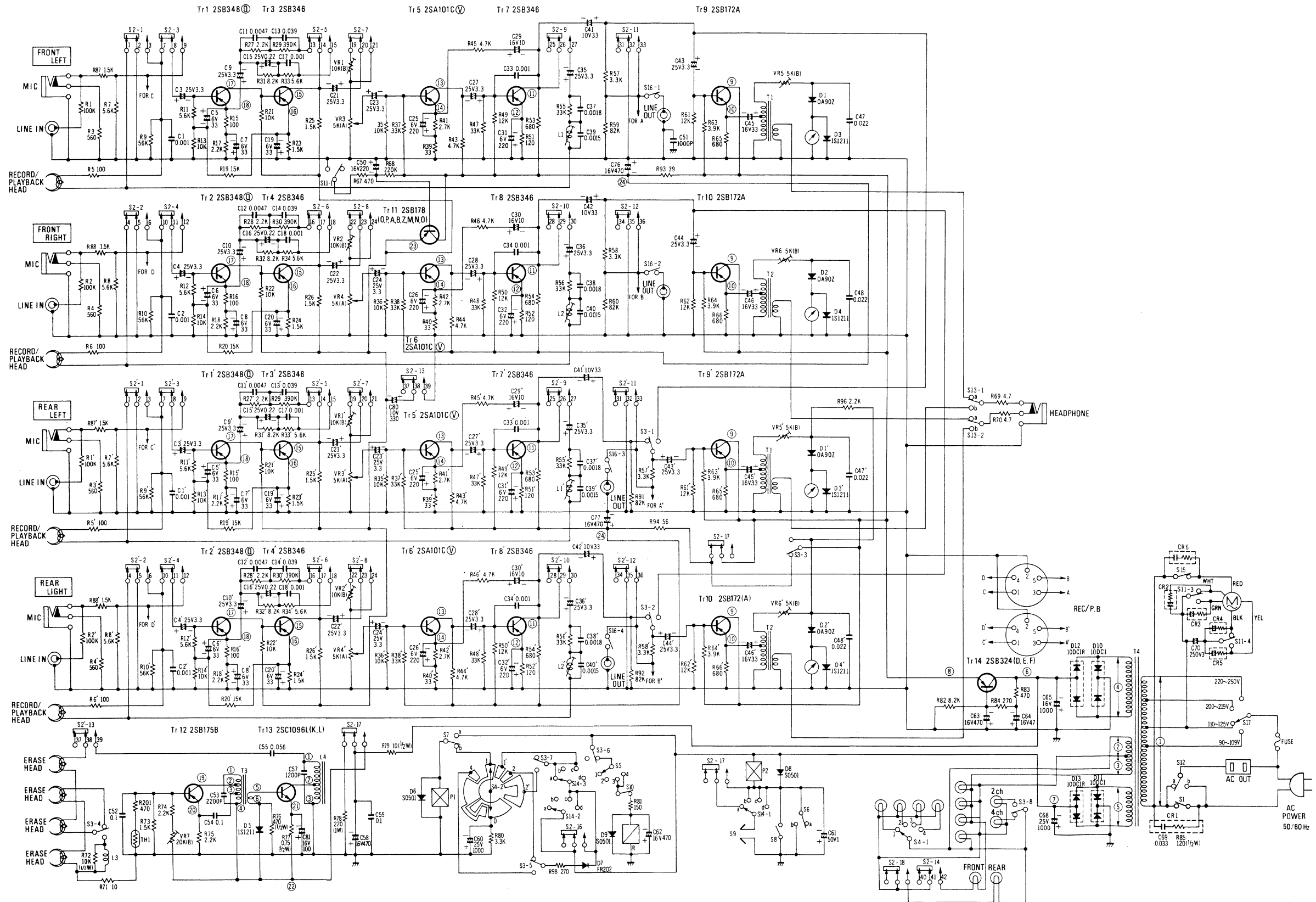

Check Point	Reco
①	STAN
②	AC
③	AC
④	AC
⑤	AC
⑥	-
⑦	-
⑧	-
⑨	-
⑩	-
⑪	-
⑫	-

NOTE: All min Use

- NOTE:
- S1 .....
  - S2-1 ~ S2-17 ~
  - S3-1 ~
  - S4-1, S4-2, S4-3, S4-4
  - S5 .....
  - S6 .....
  - S7 .....
  - S8 .....
  - S9 .....
  - S10 .....
  - S11-1, S11-2, S11-3, S11-4
  - S12 .....
  - S13-1, S13-2, S13-3, S13-4
  - S14-1, S14-2, S14-3, S14-4
  - S15 .....
  - S16-1, S16-2, S16-3, S16-4
  - S17 .....
  - S18 .....
  - S19 .....
  - S20 .....
  - S21 .....
  - Resistor K=1.0, P=Picc
  - Capacit
  - Encircle

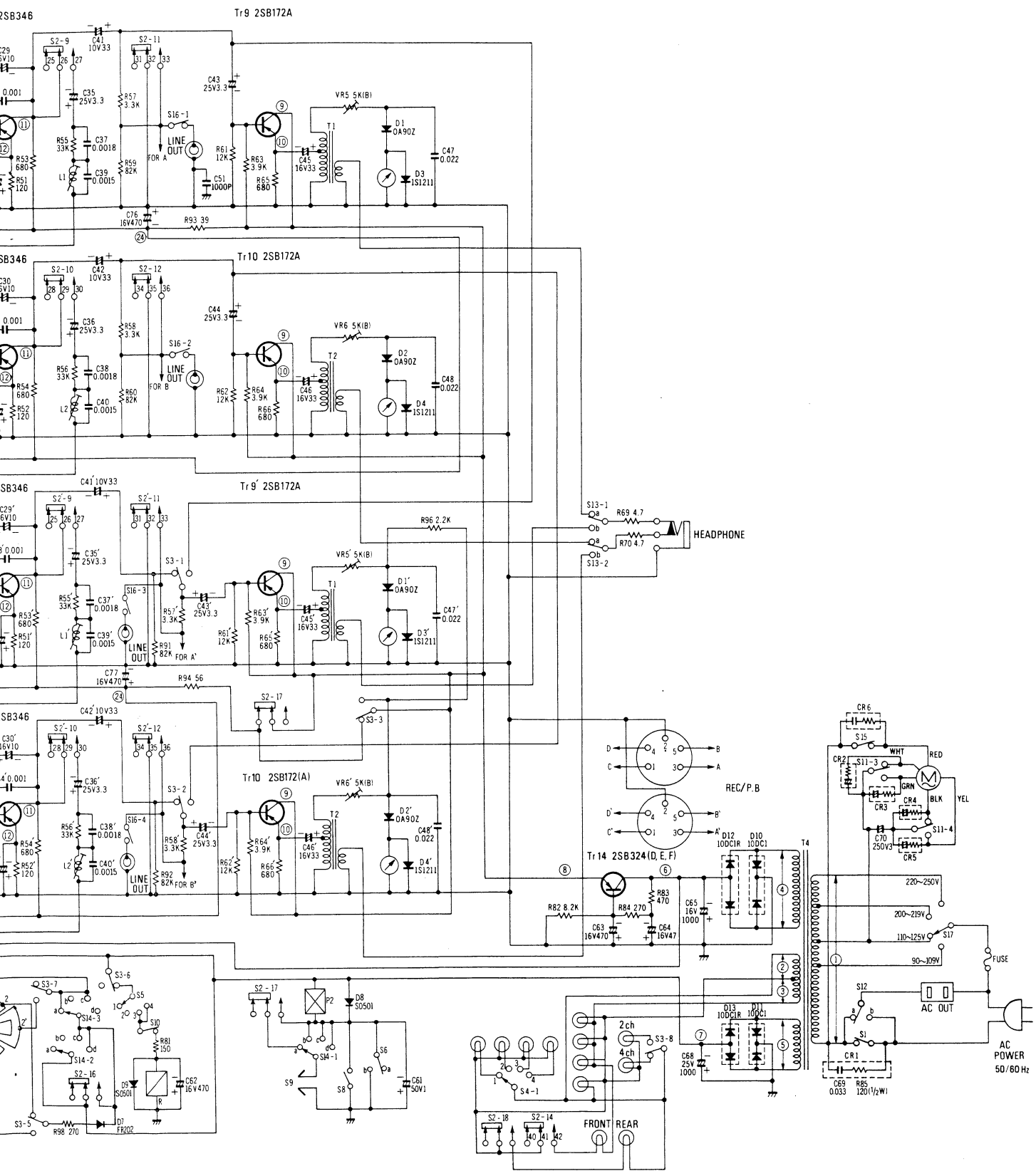

**STANDARD VOLTAGE CHART**

Check Point	Recording	Playback	Check Point	Recording	Playback
①	STANDARD	STANDARD	⑬	-7.1V	-7.1V
②	AC 5.9V	AC 5.9V	⑭	-2.30V	-2.30V
③	AC 5.9V	AC 5.9V	⑮	-4.0V	-4.0V
④	AC 11.3V	AC 11.3V	⑯	-2.3V	-2.3V
⑤	AC 16.5V	AC 16.5V	⑰	-2.9V	-2.9V
⑥	-13.8V	-13.8V	⑱	-0.85V	-0.85V
⑦	-22.0V	-22.0V	⑲	-11.6V	—
⑧	-12.0V	-12.0V	⑳	-1.15V	—
⑨	-12.0V	-12.0V	㉑	-11.6V	—
⑩	-8.6V	-8.6V	㉒	-11.6V	—
⑪	-5.4V	-5.4V	㉓	-6.2V	-6.2V
⑫	-1.05V	-1.05V	㉔	-10.5V	-10.5V

**NOTE:** All measurements are under no signal conditions with volume at minimum position.  
Use VTVM for voltage measurements.

**NOTE:**

- S1 ..... Power ON/OFF switch (ON when record button is pressed or cartridge is put in).
- S2-1~S2-14 } Record/playback select switch (shown in playback position).  
S2'-1~S2'-16 }
- S3-1~S3-8 ..... 2-CH/4-CH select switch (shown in 4-CH position).
- S4-1, S4-2 ..... Program Indicator switch.
- S5 ..... Plunger switch (ON with program 3 or 4).
- S6 ..... Relay switch (a→b when relay is energized).
- S7 ..... Manual eject switch.
- S8 ..... Program select switch.
- S9 ..... Sensing switch.
- S10 ..... Relay function switch.
- S11-1~S11-4 ... Fast forward switch.
- S12 ..... AC out selector switch.
- S13-1, S13-2 ..... Headphone select switch.
- S14-1~S14-3 ..... a. Repeat b. Continuous play c. Auto eject each d. Auto eject 1→4 (1→2).
- S15 ..... Pause switch.
- S16-1~S16-4 ..... Cartridge switch.
- S17 ..... Voltage selector switch.
- VR1, 2, 1', 2' ..... Playback level adjust VR.
- VR3, 4, 3', 4' ..... Volume control.
- VR5, 6, 5', 6' ..... Level indicator adjust VR.
- VR7 ..... Erase current adjust VR.
- Resistors are ohms (Ω), 1/4 watt unless specified otherwise. K=1,000Ω
- Capacitors are microfarad (μF) unless specified otherwise. P=Pico-farads.
- Circled numbers (○) show the checkpoints for voltage.

# CIRCUIT BOARD

## MAIN CIRCUIT BOARD

# POWER CIRCUIT BOARD

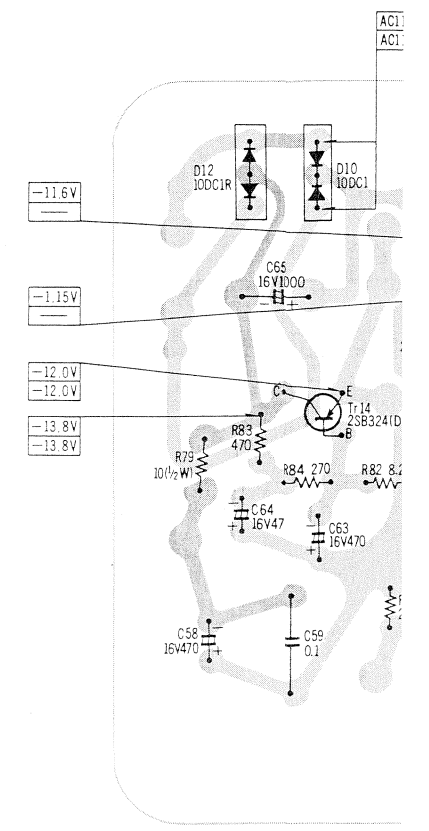
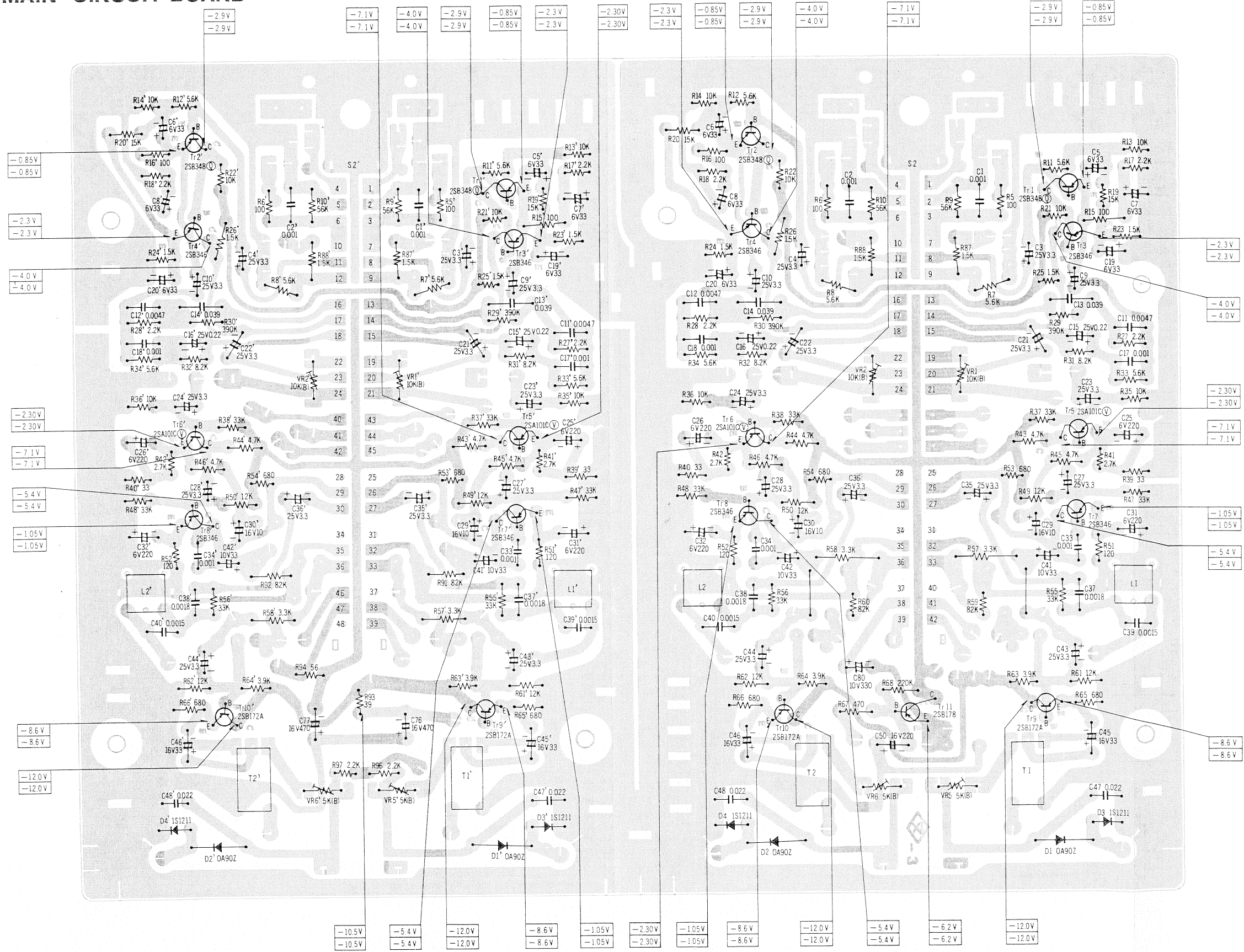



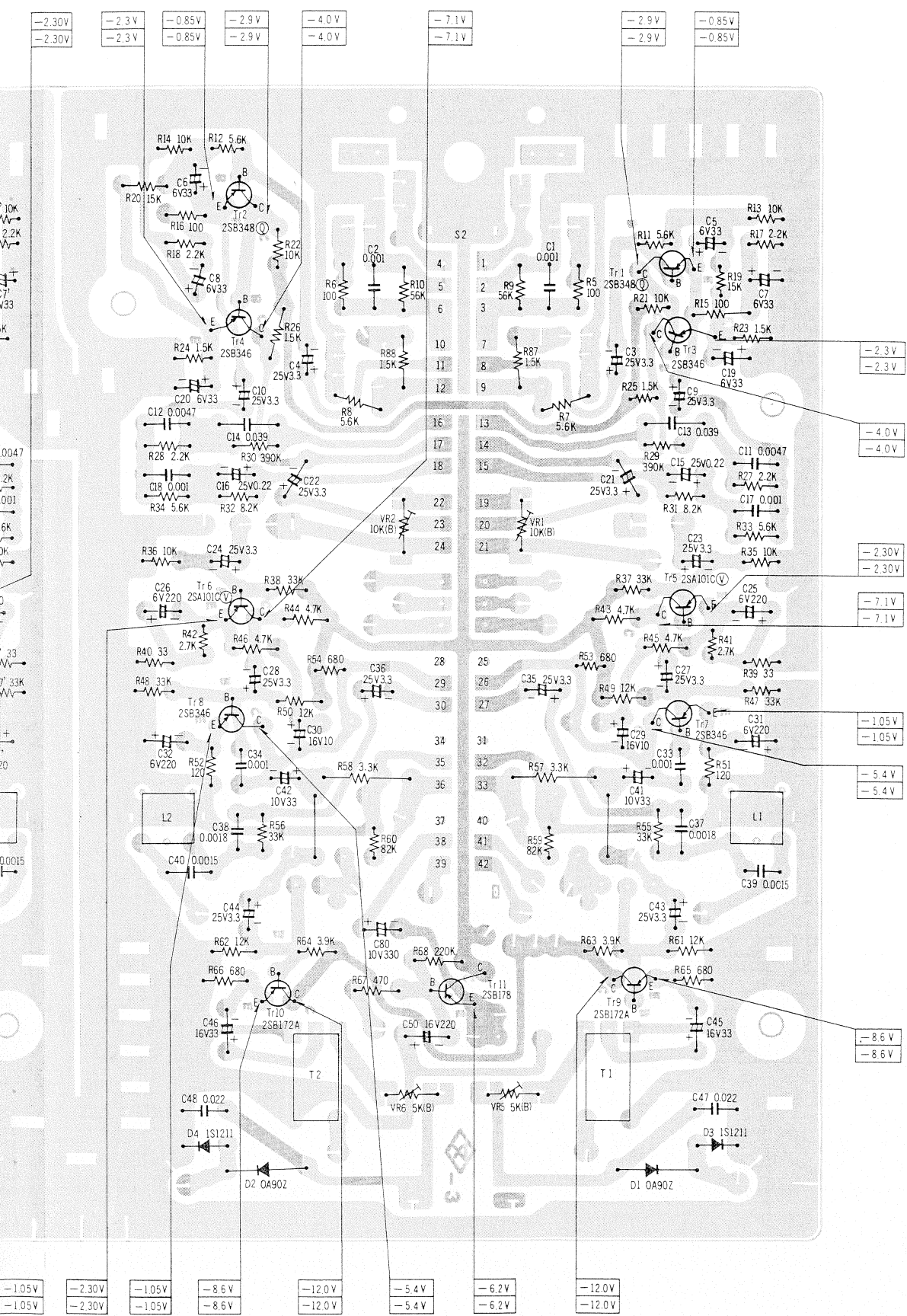

# POWER CIRCUIT BOARD

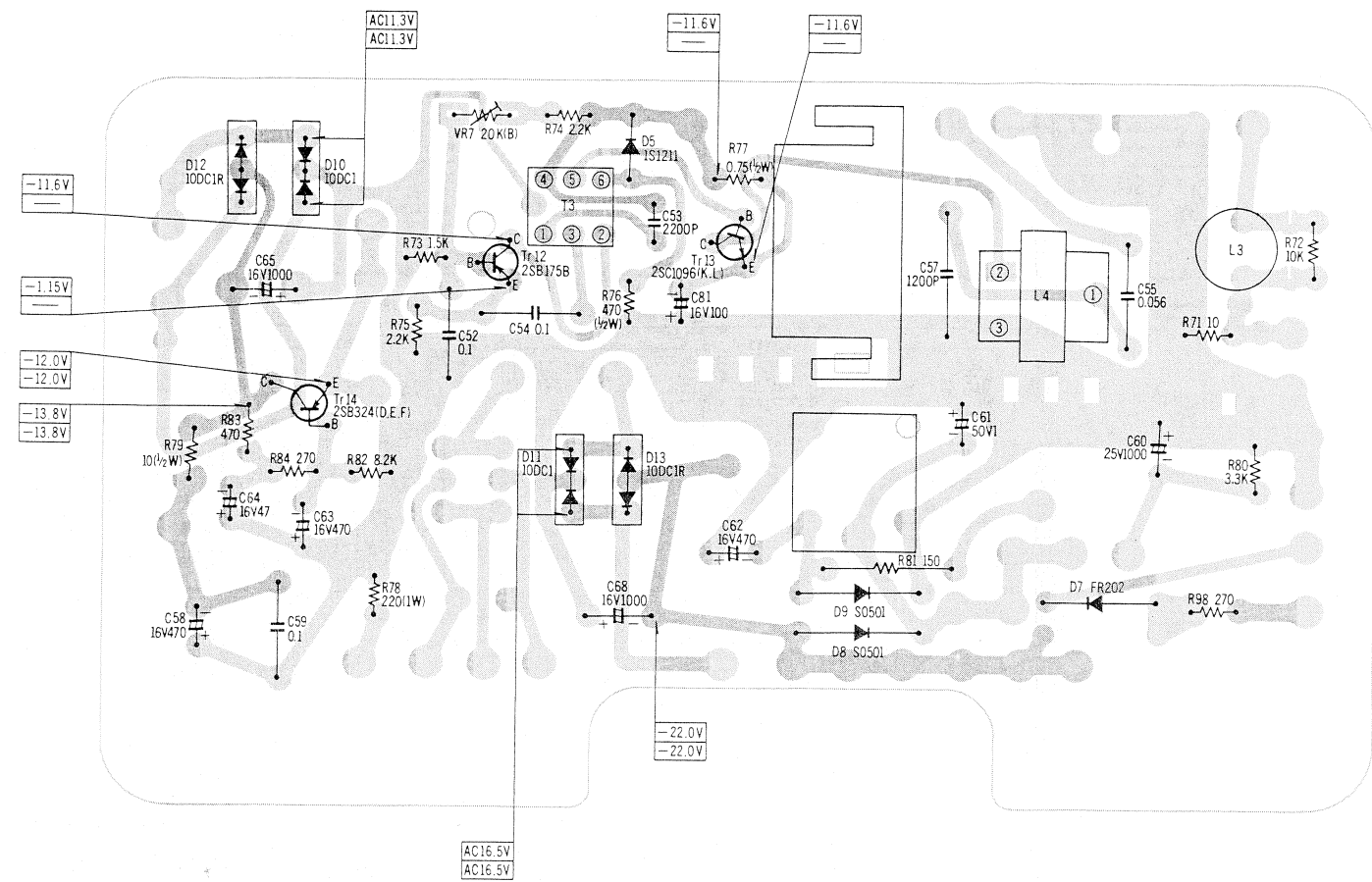

**NOTE:**  
The circuit shown in red on the conductor -B circuit.  
Values indicated in    are DC voltages between the chassis and electrical parts.  
The upper values should be measured during recording and the lower values during playback.

# EXPLODED VIEWS

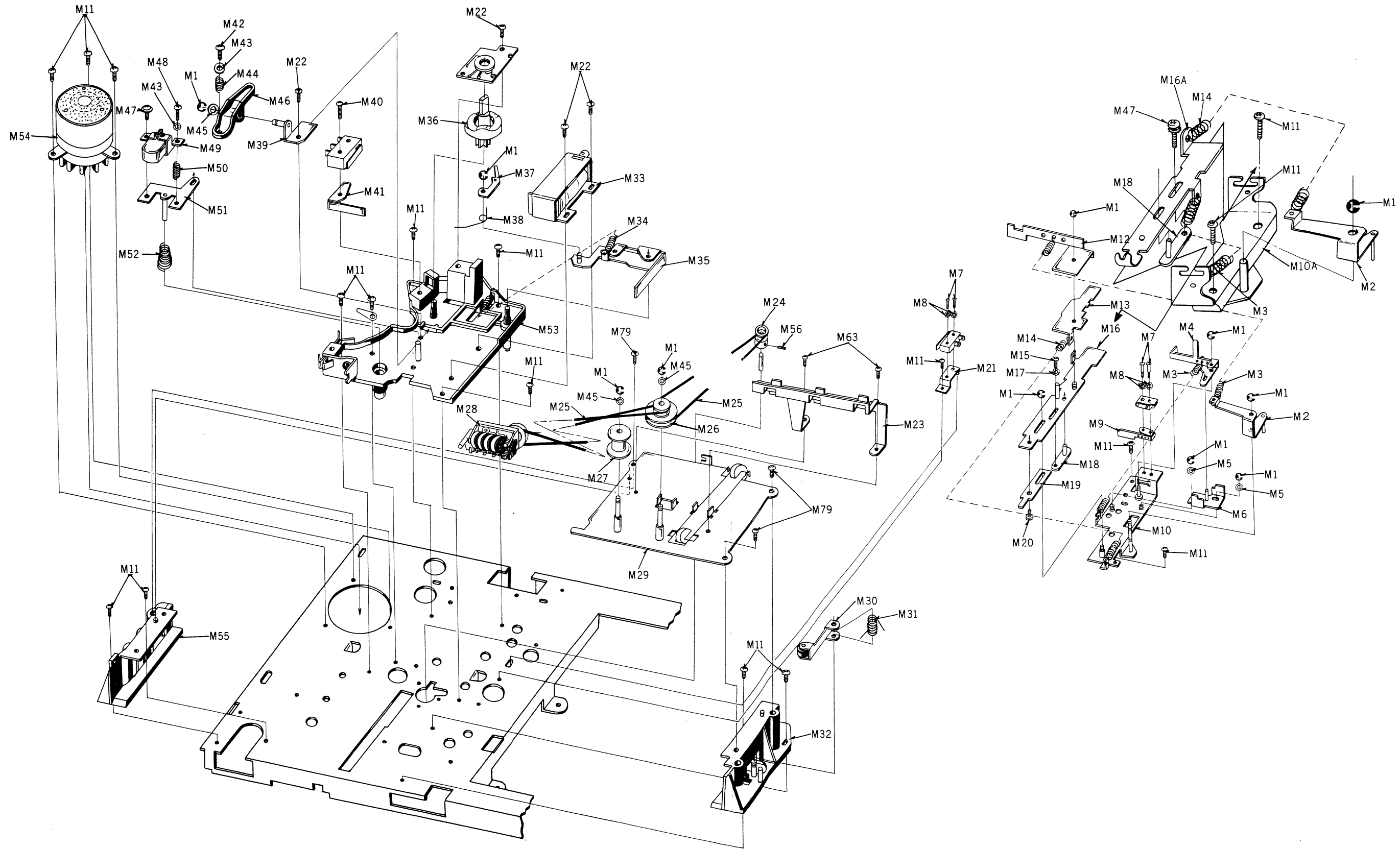

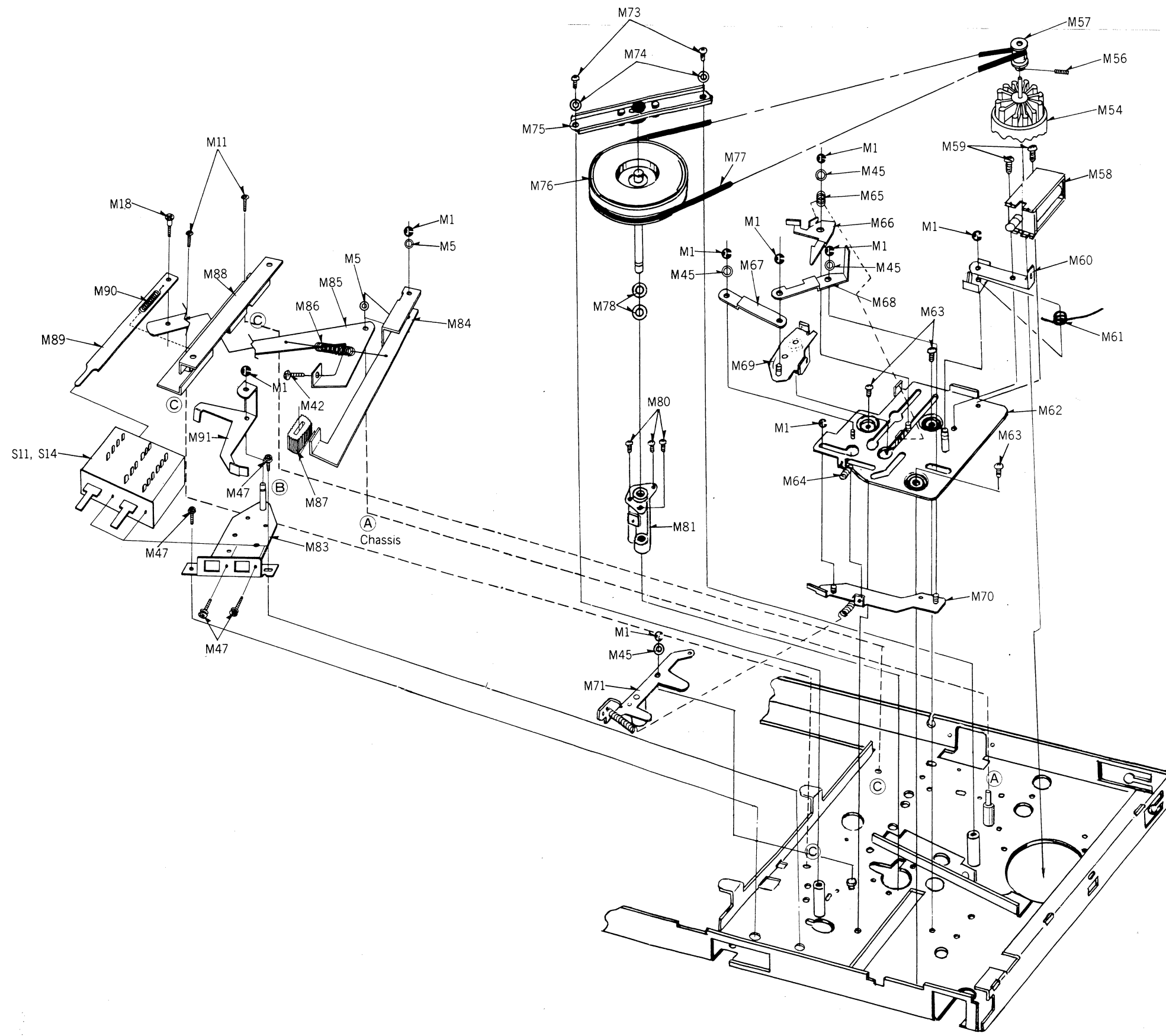

# REPLACEMENT PARTS LIST

## MODEL RS-858DUS

### (Panasonic)

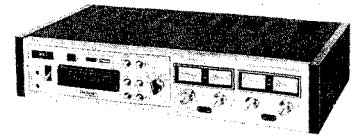

This is the parts list for PX.

**RS-858DUS**

Ref. No.	Description	Part No.	Per Set (Pcs.)	Note
<b><u>MECHANICAL PARTS</u></b>				
M1	Stop Ring E3φ	XUC3FT	20	
M2	Record Operation Lever Unit	QXL0641	2	
M2A	Record Operation Lever Spring	QBT1378T	1	
M3	Switch Operation Spring	QBT1572T	2	
M4	Lock Release Lever	QML2239	1	
M5	Fiber Washer 4.2×9×0.25	QBK7007	5	
M6	Sub Record Lock Unit	QXL0700	1	
M7	Screw ⊕2.3×11	QHQ1182	4	
M8	Lock Washer 2.3φ	XWC23C	4	
M9	Actuator	QBP1468	1	
M9A	Micro Switch Cover	QBK1170P	1	
M10	Record Angle Unit-A	QXE0183	1	
M10A	Record Angle Unit-B	QXA0160	1	
M11	Tapping Screw ⊕3×8	XTB3+8B	17	
M12	Lock Release Lever-B	QML2323A	1	
M13	Record Safety Plate	QML2326	1	
M13A	Record Safety Plate Spring	QBT1486M	1	
M14	Lock Release Spring	QBT1571T	2	
M15	Screw ⊕3×6	XSB3+6	1	
M16	Record Lever-A Unit	QXL0642	1	
M16A	Record Lever-B	QML2423	1	
M17	Lock Washer 3φ	XWC3BFY	2	
M18	Record Adjustment Plate Unit	QXL0544	2	
M19	Record Lever-B	QML2246	1	
M20	Screw	XSNQ0004S	2	
M21	Switch Holding Angle	QMA1792	1	
M22	Screw ⊕3×10	XTB3+10B	4	
M23	Cord Cramper	QMA1846	1	

Ref. No.	Description	Part No.	Per Set (Pcs.)	Note
M24	Counter Pulley	QDP1483S	1	
M25	Counter Belt	QDB0163	2	
M26	Connection Pulley-A	QDP1484	1	
M27	Connection Pulley-B	QDP1485	1	
M28	Tape Counter	QDC0055	1	
M29	Reinforcement Plate Unit	QXH0151	1	
M30	Eject Safety Lever Unit	QXL0475	1	
M31	Eject Safety Spring	QBN1220	1	
M32	Cartridge Guide-R	QMG0001A	1	
M33	Plunger	QME0130C	1	
M34	Program Selector Spring	QBT1705	1	
M35	Change Arm Unit	QXL0679	1	
M36	Cam	QMF1486	1	
M37	Ratchet Plate	QMF1593	1	
M38	Ratchet Spring	QBN1249	1	
M39	Operating Arm Retainer Unit	QXH0115	1	
M40	Tapping Screw $\oplus 2 \times 12$	XTN2+12B	1	
M41	Stop Spring	QBP1400	1	
M42	Head Height Adjust Screw	QH1088	1	
M43	Fiat Washer $3\phi$	XWG3FX	4	
M44	Head Height Adjust Spring	QBC1167	1	
M45	Fiber Washer $4.2 \times 9 \times 0.5$	QBK7005	7	
M46	Operation Arm	QML2058	1	
M47	Sems Screw $\oplus 3 \times 6$	XYN3+C6	4	
M48	Screw $\ominus 3 \times 10$	XSN3-10	1	
M49	Head Holding Angle	QMH1184	1	
M50	Head Angle Adjust Spring	QBC1166	1	
M51	Vertical Table Unit	QXH0113	1	
M52	Head Pressure Spring	QBC1168	1	
M53	Head Base Plate Unit with S9	QXK1431	1	
M54	Motor Assembly	QDM1311	1	
M54-1	Rubber Cushion	QBG1349	3	
M54-2	Spacer	QMP1418	3	
M55	Cartridge Guide-L Assembly	QXQ0065	1	
M56	Motor Pulley Set Screw	XXE3D5FZS	2	



Ref. No.	Description	Part No.	Per Set (Pcs.)	Note
M57	Motor Pulley	QDP1504S	1	
(M57)	Motor Pulley for Adjustment ⊕	QDP1522S	(1)	
(M57)	Motor Pulley for Adjustment ⊖	QDP1523S	(1)	
M58	Plunger	QME0129C	1	
M59	Tapping Screw ⊕3×6	XTB3+6B	2	
M60	Lock Release Lever	QML2404	1	
M61	Lock Release Lever Spring	QBN1282	1	
M62	Eject Plate Unit	QXH0138	1	
M63	Sems Screw ⊕3×4	XYN3+C4	5	
M64	Return Spring	QBT1576M	1	
M65	Eject Spring	QBN1177	1	
M66	Toggle Plate-C	QMF1435A	1	
M67	Right Toggle Plate	QMF1432	1	
M68	Left Toggle Plate Assembly	QXL0783	1	
M69	Lock Arm Unit	QXH0139	1	
M70	Toggle Plate Unit	QXL0519	1	
M71	Lock Lever Unit	QXL0704	1	
M72	Lock Lever Spring	QBT1648	1	
M75	Flywheel Retainer Unit	QXH0154	1	
M76	Flywheel Unit	QXF0084	1	
M77	Flywheel Belt	QDB0170	1	
M78	Poly Washer 6.2×13×0.25	QBJ3299	2	
M78A	Oil Prevention Washer	QBG1351	1	
M79	Tapping Screw ⊕3×12	XTB3+12B	3	
M80	Screw ⊕3×6	XST3+6	3	
M81	Capstan Metal Unit	QXQ0055A	1	
M82	Angle Spacer	QTW1082P	1	
M83	Pause Angle Unit	QXE0188	1	
M84	Screw	QHQ1088	1	
M85	Tapping Screw ⊖3×14	XTB3+14B	3	
M86	Belt Guide Spring	QBN1404	1	
M87	Wire Guide Plate	QMF1706	1	
M88	Fast Forward Release Lever	QML2322	1	
M89	Reinforcement Angle	QMA2063S	1	
M90	Main Brake Lever	QML2542A	1	

Ref. No.	Description	Part No.	Per Set (Pcs.)	Note
M91	Brake Lever	QML2543	1	
M92	Main Brake Lever Spring	QBT1689	1	
M93	Brake Shoe	QBG1414	1	
M94	Brake Rod	QMR1319	1	
M95	Brake Rod Spring	QBT1690	1	
	<b><u>RESISTORS</u></b>			
R1, 2, 1', 2'	Carbon Resistor 100 K $\Omega$ 1/4 W	ERD14VJ104	4	
R3, 4, 3', 4'	" 390 $\Omega$ 1/4 W	ERD14VJ391	4	
R5, 6, 15, 16, 5', 6', 15', 16'	" 100 $\Omega$ 1/4 W	ERD14VJ101	8	
R7, 8, 33, 34, 7', 8', 33', 34'	" 5.6 K $\Omega$ 1/4 W	ERD14VJ562	8	
R11, 12, 11', 12'	" 18 K $\Omega$ 1/4 W	ERD14VJ183	4	
R17, 18, 23, 24, 25', 26'	25, 26, 74, 75, 96, 97, 17', 18', 23', 24', 25', 26'			
	" 2.2 K $\Omega$ 1/4 W	ERD14VJ222	16	
R19, 20, 55, 56, 251, 19', 20', 55', 56'	" 22 K $\Omega$ 1/4 W	ERD14VJ223	9	
R21, 22, 35, 36, 21', 22', 35', 36'	" 10 K $\Omega$ 1/4 W	ERD14VJ103	8	
R27, 28, 47, 48, 73, 27', 28', 47', 48'	" 1.5 K $\Omega$ 1/4 W	ERD14VJ152	9	
R29, 30, 29', 30'	" 180 K $\Omega$ 1/4 W	ERD14VJ184	4	
R31, 32, 82, 31', 32'	" 8.2 K $\Omega$ 1/4 W	ERD14VJ822	5	
R37, 38, 37', 38'	" 33 K $\Omega$ 1/4 W	ERD14VJ333	4	
R39, 40, 39', 40'	" 33 $\Omega$ 1/4 W	ERD14VJ330	4	
R41, 42, 41', 42'	" 2.7 K $\Omega$ 1/4 W	ERD14VJ272	4	
R43, 44, 45, 46, 43', 44', 45', 46'	" 4.7 K $\Omega$ 1/4 W	ERD14VJ472	8	
R49, 50, 61, 62, 49', 50', 61', 62'	" 12 K $\Omega$ 1/4 W	ERD14VJ123	8	
R51, 52, 51', 52'	" 120 $\Omega$ 1/4 W	ERD14VJ121	4	
R53, 54, 65, 66, 53', 54', 65', 66'	" 680 $\Omega$ 1/4 W	ERD14VJ681	8	
R57, 58, 80, 57', 58'	" 3.3 K $\Omega$ 1/4 W	ERD14VJ332	5	
R59, 60, 91, 92	" 82 K $\Omega$ 1/4 W	ERD14VJ823	4	
R63, 64, 63', 64'	" 3.9 K $\Omega$ 1/4 W	ERD14VJ392	4	

Ref. No.	Description	Part No.	Per Set (Pcs.)	Note
R67, 83, 201	Carbon Resistor 470 $\Omega$ 1/4 W	ERD14VJ471	3	
R68	" 330 K $\Omega$ 1/4 W	ERD14VJ334	1	
R69, 70, 87, 88, 69', 70', 87', 88'				
	" 820 $\Omega$ 1/4 W	ERD14VJ821	8	
R71, 253, 254, 253', 254'	" 10 $\Omega$ 1/4 W	ERD14VJ100	5	
R72	Solid Resistor 10 K $\Omega$ 1/2 W	ERC12GM103	1	
R76	" 470 $\Omega$ 1/2 W	ERC12GM471	1	
R77	Wire-wound Resistor 0.75 $\Omega$ 1/2 W	ERW12PJR75	1	
R78	Solid Resistor 220 $\Omega$ 1 W	ERC1GM221	1	
R79	" 10 $\Omega$ 1/2 W	ERC12GM100	1	
R81	Carbon Resistor 150 $\Omega$ 1/4 W	ERD14VJ151	1	
R84, 98	" 270 $\Omega$ 1/4 W	ERD14VJ271	2	
R93	" 39 $\Omega$ 1/4 W	ERD14VJ390	1	
R94	" 56 $\Omega$ 1/4 W	ERD14VJ560	1	
R252	" 39 K $\Omega$ 1/4 W	ERD14VJ393	1	
R270	Metal Oxide Resistor 47 $\Omega$ 2 W	ERG2ANJ470	1	
	<b><u>VARIABLE RESISTORS</u></b>			
VR1, 2, 1', 2'	Semi-fixed Variable Resistor 10 K $\Omega$ (B)	EVLS3AA00B14	4	
VR3, 4, 3', 4'	Variable Resistor 5 K $\Omega$ (A)	EVCB7AK30A53	4	
VR5, 6, 5', 6'	Semi-fixed Variable Resistor 5 K $\Omega$ (B)	EVLS3AA00B53	4	
VR7	" 20 K $\Omega$ (B)	EVLS3AA00B24	1	
	<b><u>CAPACITORS</u></b>			
C1, 2, 33, 34, 1', 2', 33', 34'	Mylar Capacitor 0.001 $\mu$ F	ECQM05102MZ	8	
C3, 4, 9, 10, 21, 22, 23, 24, 35, 36, 41, 42, 43, 44, 3', 4', 9', 10', 21', 22', 23', 24', 35', 36', 41', 42', 43', 44'				
	Electrolytic Capacitor 3.3 $\mu$ F	ECEA25V3R3	28	
C7, 8, 19, 20, 7', 8', 19', 20'	" 33 $\mu$ F	ECEA6V33L	8	
C11, 12, 11', 12'	Mylar Capacitor 0.018 $\mu$ F	ECQM05183MZ	4	
C13, 14, 13', 14'	" 0.039 $\mu$ F	ECQM05393MZ	4	
C15, 16, 15', 16'	Electrolytic Capacitor 0.22 $\mu$ F	ECEA25VR22M	4	
C25, 26, 31, 32, 25', 26', 31', 32'				
	" 220 $\mu$ F	ECEA6V220L	8	
C27, 28, 27', 28'	Aluminum Capacitor 0.22 $\mu$ F	ECAG25ER22M	4	
C29, 30, 29', 30'	Electrolytic Capacitor 10 $\mu$ F	ECEA16V10L	4	

Ref. No.	Description	Part No.	Per Set (Pcs.)	Note
C37,38,37',38'	Mylar Capacitor	0.0018 $\mu$ F	ECQM05182MZ	4
C39,40,39',40'	"	0.0022 $\mu$ F	ECQM05222MZ	4
C45,46,45',46'	Electrolytic Capacitor	33 $\mu$ F	ECEA16V33L	4
C50	"	220 $\mu$ F	ECEA16V220L	1
C51	Ceramic Capacitor	0.001 $\mu$ F	ECKD1H102PF2	1
C52, 54, 59	Mylar Capacitor	0.1 $\mu$ F	ECQM05104MZ	3
C53	Styrol Capacitor	2200 pF	ECQS1222JZ	1
C55	Mylar Capacitor	0.056 $\mu$ F	ECQM05563MZ	1
C56	Electrolytic Capacitor	100 $\mu$ F	ECEA16V100L	1
C57	Styrol Capacitor	1200 pF	ECQS5122J	1
C58,62,63,76, 77,101	Electrolytic Capacitor	470 $\mu$ F	ECEA16V470L	6
C60, 68	"	1000 $\mu$ F	ECEA25V1000L	2
C61, 263, 264, 263', 264'	"	1 $\mu$ F	ECEA50V1L	5
C64	"	47 $\mu$ F	ECEA16V47L	1
C65	"	1000 $\mu$ F	ECEA16V1000L	1
C78	"	100 $\mu$ F	ECEA6V100L	1
C80	"	330 $\mu$ F	ECEA10V330L	1
C102	"	330 $\mu$ F	ECEA16V330L	1
C103, 104, 103', 104'	"	0.68 $\mu$ F	ECEA50VR68ML	4
C261, 262, 261', 262'	"	0.022 $\mu$ F	ECQM05223MZ	4
<b><u>TRANSISTORS</u></b>				
Tr1, 2, 1', 2'	Transistor		2SB348@	4
Tr3, 4, 7, 8, 3', 4', 7', 8'	"		2SB346	8
Tr5, 6, 5', 6'	"		2SA101C@	4
Tr9, 10, 9', 10'	"		2SB172A	4
Tr11	"		2SB178 (O,P,A,B,Z,M,N,Q)	1
Tr12	"		2SB175B	1
Tr13	"		2SC1096L(K,L)	1
Tr14	"		2SB324(D,E,F)	1
Tr15, 16, 15', 16'	"		2SA564	4
<b><u>DIODES &amp; RECTIFIERS</u></b>				
D1, 2, 1', 2'	Diode		OA90Z	4
D3, 4, 3', 4'	Silicon Diode		1S1211	5

Ref. No.	Description	Part No.	Per Set (Pcs.)	Note
D6, 8, 9	Silicon Diode	S0501	3	
D7, 10	"	FR202	2	
D11, 12, 13	Silicon Rectifier	10DC1	3	
D14, 15, 16	"	10DC1R	3	
<b><u>TRANSFORMERS</u></b>				
T1, 2, 1', 2'	Headphone Transformer	QLA0349	4	
T3	Oscillator Transformer	QLB0141	1	
T4	Power Transformer	QLP0721	1	
<b><u>COILS</u></b>				
L1, 2, 1', 2'	Trap Coil	ELM10S206	4	
L3	Erase Head Dummy Coil	ELQ4C1	1	
L4	Oscillator Output Transformer	QLB0138	1	
<b><u>COMBINATION PART</u></b>				
Z1	CR Combination	QCR0008	1	
<b><u>THERMISTOR</u></b>				
TH1	Thermistor	QVM302A	1	
<b><u>SWITCHES</u></b>				
S1	Micro Switch (Power ON/OFF)	QSM0049	1	
S2, 2	Slide Switch (Record/Playback)	QSS1146	2	
S3	Push Button (4/2-Channel)	QSW0204SA	1	
S4	Rotary Switch (Program Indicator)	QSR0019	1	
S5	Micro Switch (Plunger)	QSM0040A	1	
S6	Relay Switch	QSK0123A	1	
S7	Push Switch (Manual Eject)	QSW0118SA	1	
S8	Push Switch (Program Select)	QSW0116SA	1	
S9	Sensing Switch	(Refer M53)	(1)	
S10	Micro Switch (Relay)	QSM0040A	1	
S11	Push Switch (Fast Forward)	QSW0127S	1	
S12	Lever Switch (AC OUT)	QST0039S	1	
S13	Pause Switch	(Refer S11)	(1)	

Ref. No.	Description	Part No.	Per Set (Pcs.)	Note
S14	Rotary Switch (Operation Selector)	ESRE244K25Z	1	
S15	Rotary Switch (AC Voltage Selector)	QSR0004B	1	
S16	Slide Switch (Cartridge)	QSS1107	1	
<b><u>JACKS</u></b>				
J1, 2, 1', 2'	Microphone Jack	QJA0427	2	
J3, 4, 3', 4'	LINE IN Jack	(Refer E3)	(4)	
J5, 6, 5', 6'	LINE OUT Jack	(Refer E4)	(4)	
J7, 7'	Headphone Jack	QJA0229	2	
<b><u>PILOT LAMPS</u></b>				
PL1	Pilot Lamp (Program Indicator)	XAMQ15S	1	
PL2, 3, 4, 5	Pilot Lamp (Level Meter Lamp)	XAMQ16P400	4	
PL6, 7	Pilot Lamp (4/2-Channel Indicator)	XAMP16P400	2	
PL8, 9	Pilot Lamp (Record Indicator)	XAMQ11P300	2	
<b><u>ELECTRICAL PARTS</u></b>				
E1	Head (Record/Playback/Erase)	QWY8004A	1	
E2	Level Meter	QSL1016L	4	
E3	Jack Plate-1 Assembly	QEJ0256	1	
E4	Jack Plate-2 Assembly	QEJ0257	1	
E5	AC Power Cord	QFC1041	1	
E6	Cord Bushing	QTD1126A	1	
E7	Rubber Bush	QBG1239	1	
E8	Heat Sink for Tr13	QTH1091S	1	
E9	Heat Sink for Tr14	QTH1028	1	
E10	6P Terminal Board	QJT6009	3	
E11	4P Lug Terminal	QJT4012	1	
E12	AC Socket	QJS0317	1	
E13	Fuse	XBA1E10NR3	1	
E14	Fuse Holder	QEQ1206	1	
<b><u>CABINET PARTS</u></b>				
G1	Main Body Case Assembly	QYB0350S	1	
G2	Bottom Plate	QKU1564	1	

Ref. No.	Description	Part No.	Per Set (Pcs.)		Note
G3	Panel Assembly	QYP0521	1		
G3-1	Cartridge Lid	QKF1432	1		
G3-2	Cartridge Lid Spring	QBC1090	1		
G3-3	Cartridge Lid Rod	QMR1075	1		
G4	Volume Control Knob	QYT0286K	4		
G5	Button Assembly	QYT0114	5		
G6	Record Button	QXB0143	1		
G7	See-Saw Knob	QGT3045S	1		
G8	Selector Knob	QYT0287K	1		
G9	Screw $\oplus 4 \times 8$	XSN4+8RS	10		
G10	Tapping Screw $\oplus 3 \times 8$	XTV3+8BR	4		
G11	"	XTV3+8B	7		
G12	Rubber Foot	QKA1050	4		
G13	Screw $\oplus 3 \times 8$	XTS3+8B	5		
G14	Screw $\oplus 3 \times 6$	XSN3+6FZS	2		
<b><u>ACCESSORIES</u></b>					
A1	Cartridge Tape (Demonstration)	QFT80GPTADZ	1		
A2	Connection Cord-G	RP8125 (QEB0060P)	4		
A3	Head Cleaning Bar	QFQ1025	1		
A4	Instruction Book	QQT07001	1		
<b><u>PACKINGS</u></b>					
P1	Inside Packing	QPN3095	1		
P2	Inner Cushion	QPN2831	2		
P3	Poly Sheet	QPQ1082	2		
P4	Spacer	QPN2907	1		
P5	"	QPN2910	1		
P6	"	QPA0033	1		
P7	Dust Cover	XZB70X60A05	1		

# Service Manual

**Technics**  
by Panasonic

TAPE RECORDER

**Technics**  
by Panasonic

## 4/2-CHANNEL RECORD/PLAYBACK 8-TRACK CARTRIDGE DECK

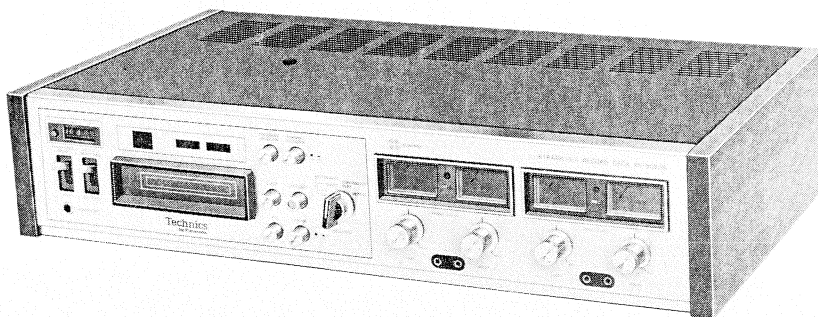

This is the Service Manual of Model RS-858US for PX.

# MODEL RS-858US

### SPECIFICATIONS

Power Source:	AC: 90~109/110~125/200~219/ 220~250 volts, 50/60 Hz	Frequency Response:	30~15,000 Hz
Power Consumption:	Approx. 55 W	Inputs:	4 "MIC" -71 dB (0.28 mV)/applicable mic impedance 200~600Ω 4 "LINE" -25 dB (56 mV)/100 KΩ
Motor:	AC outer rotor motor	Outputs:	4 "LINE" -2 dB (800 mV)/3.3 KΩ "HEADPHONES" 8Ω
Track System:	8-track, 4-channel stereo recording and playback	Program Time:	30 minutes stereo recording at 3-3/4 ips. with 300 feet tape
Recording System:	AC bias, AC erase	Dimensions:	21-1/8" (W) × 4-3/4" (H) × 11-1/4" (D)
Tape Speed:	3-3/4 ips.	Weight:	20-3/4 lbs.
Fast Forward Time:	Approx. 100 seconds for 100 feet tape		

These specifications are subject to change in order to accommodate improvements in design.

**PANASONIC TOKYO**  
**DIVISION OF MATSUSHITA ELECTRIC INDUSTRIAL CO., LTD.**

8-2, 4-chome, Shiba, Minato-ku, Tokyo 108 Japan  
Tel. (453) 3111 (Ext. 611, 612), 0421  
Cable Address: "NATIONAL TOKKI" TOKYO

ORDER NO. ARD-7305068



# LOCATION OF PARTS

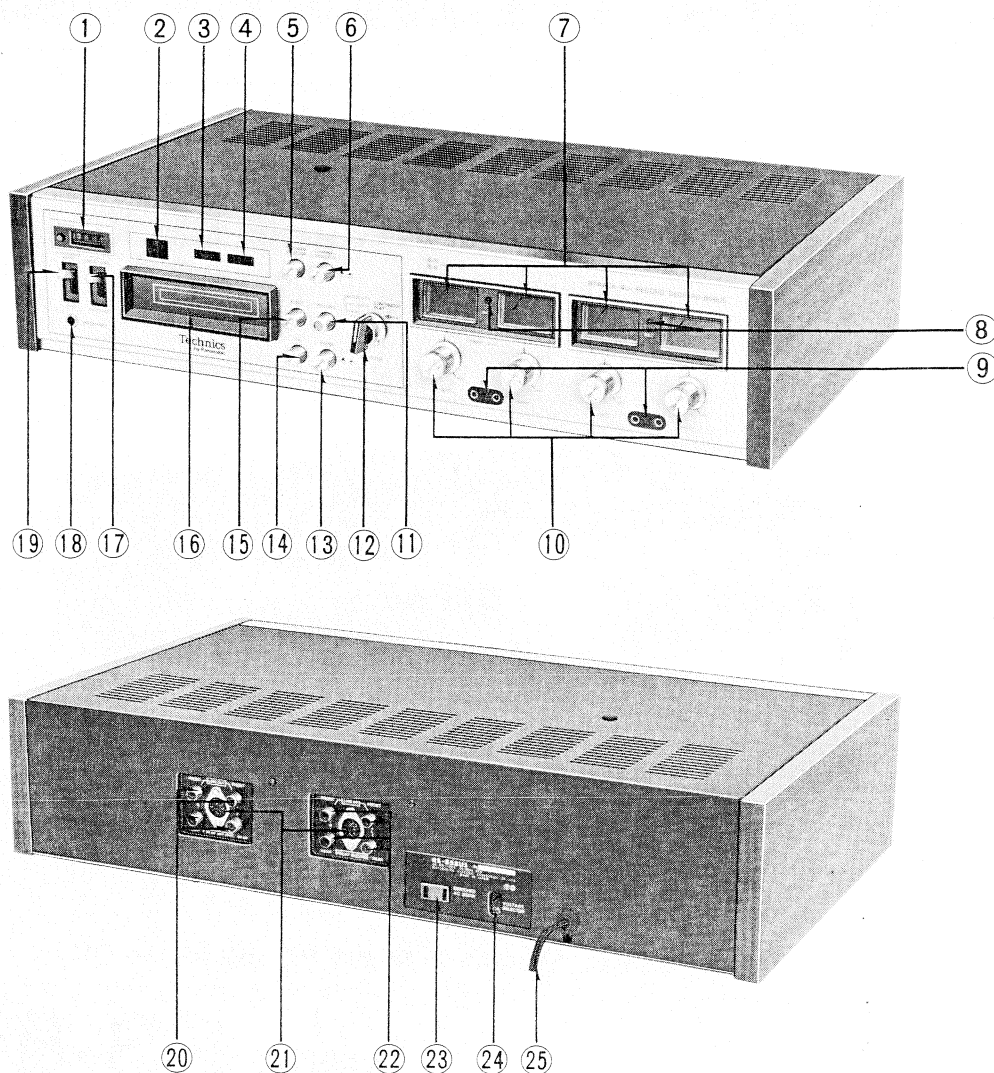
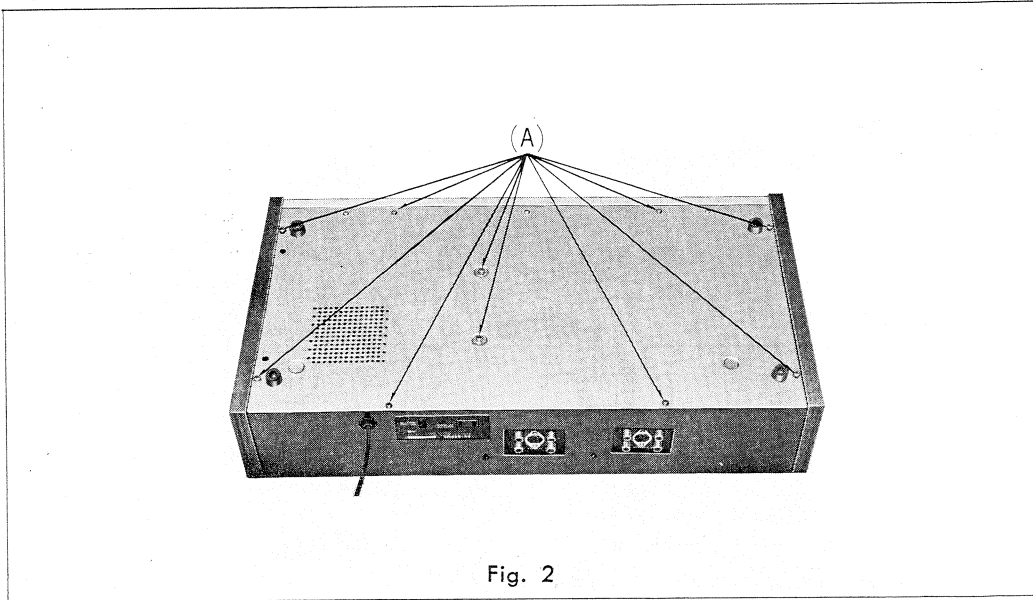

Fig. 1

- |                             |                                |
|-----------------------------|--------------------------------|
| ① Time counter              | ⑭ Fast forward button          |
| ② Program indication lamp   | ⑮ Ejection button              |
| ③ 2-channel indication lamp | ⑯ Tape slot                    |
| ④ 4-channel indication lamp | ⑰ Automatic ejection switch    |
| ⑤ Program selection button  | ⑱ Headphones jack              |
| ⑥ 2-4 channel selector      | ⑲ Headphones selector          |
| ⑦ Level meters              | ⑳ Line output jacks            |
| ⑧ Recording indicators      | ㉑ Recording/playback connector |
| ⑨ Microphone jacks          | ㉒ Line input jacks             |
| ⑩ Volume controls           | ㉓ AC power socket              |
| ⑪ Record button             | ㉔ Voltage selector             |
| ⑫ Operation selector        | ㉕ Power cord                   |
| ⑬ Pause button              |                                |

# DISASSEMBLY INSTRUCTIONS

## HOW TO REMOVE BOTTOM PLATE



1. Remove 10 bottom plate holding screws (A).
2. Then bottom plate can be removed.

---

## HOW TO REMOVE CHASSIS AND PANEL

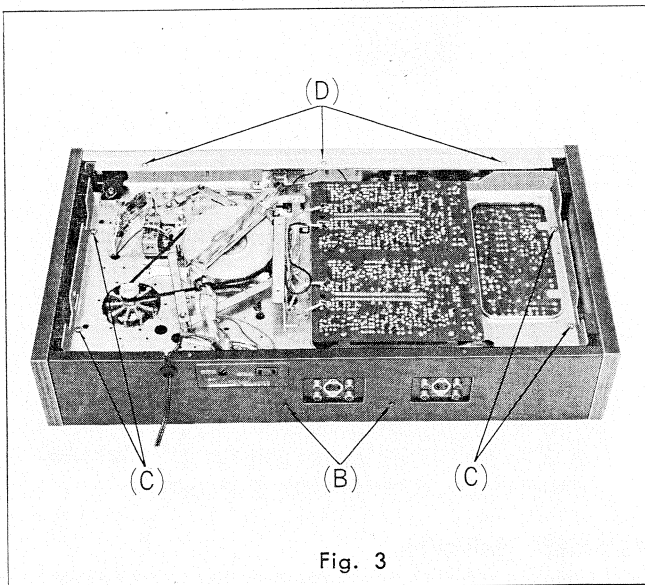

Fig. 3

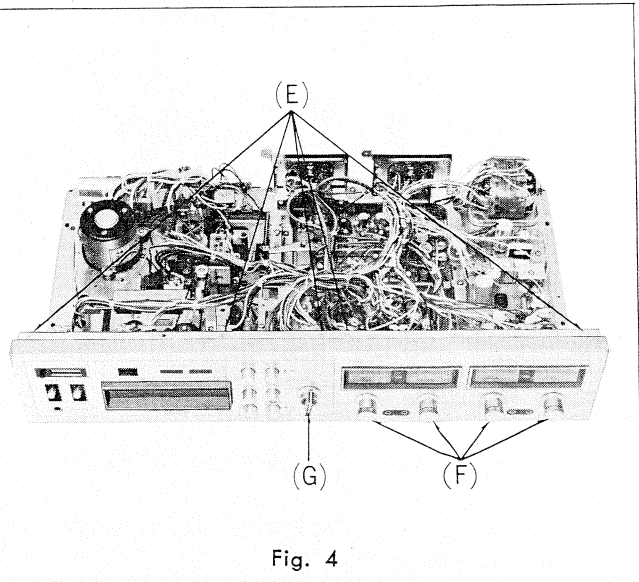

Fig. 4

1. Remove 2 body case holding screws (B) and 4 chassis holding screws (C).
2. Remove the chassis by pulling it out to the panel side.
3. Remove 3 panel holding screws (D) and 5 panel holding screws (E).
4. Remove 4 control knobs (F) and 1 selector knob (G).
5. Then panel can be removed.

# MECHANICAL ADJUSTMENTS

## PROGRAM SELECTION

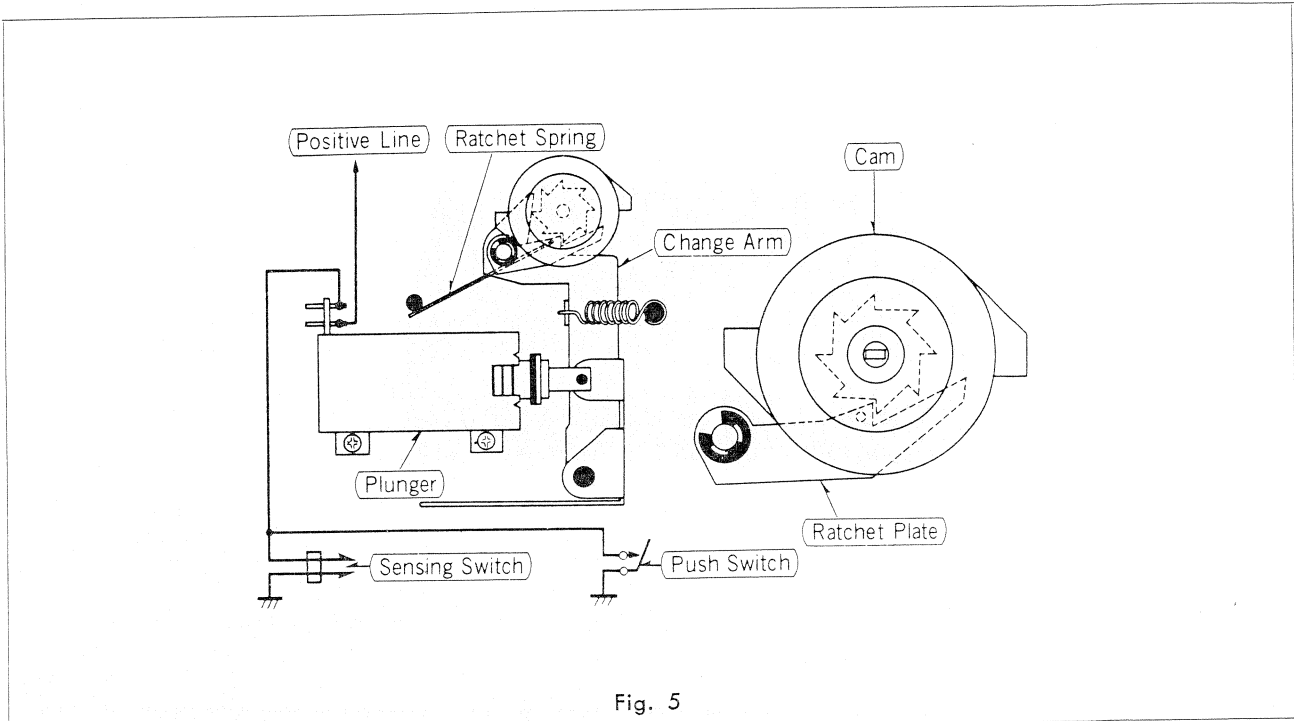

Fig. 5

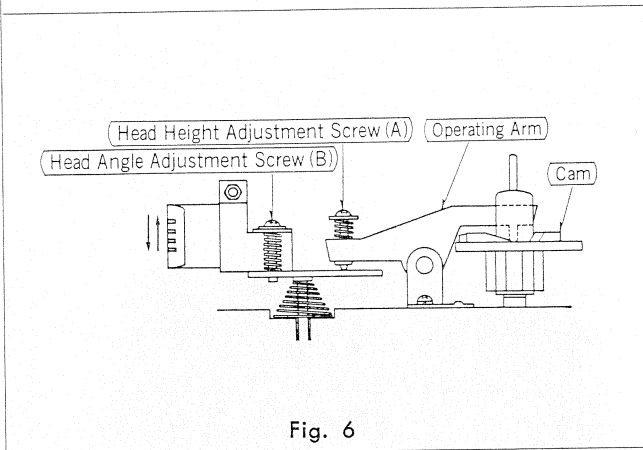

Fig. 6

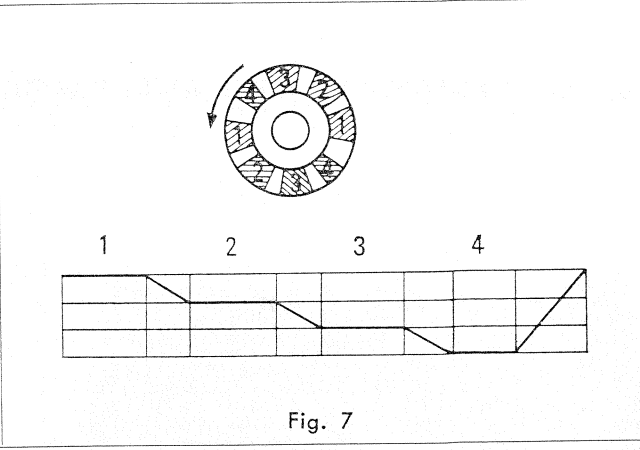

Fig. 7

### Manual Selection

1. When the push switch is pressed, the plunger operates.
2. The plunger pulls the change arm to left momentarily: then it returns to the right.
3. Change arm moves the ratchet plate which turns the cam when it returns to the right.
4. As the cam rotates, the head moves up and down and the program is selected.

### Automatic Selection

If the sensing foil is attached to the cartridge tape, the plunger functions when the sensing switch is closed by the sensing foil, thereby selecting a program can be made automatically.

Fig. 7 shows a cross-section of the cam. The convex portion of the operating arm hits upon surfaces 1, 2, 3, and 4. When it hits upon surface 4 the head is placed in top position selects program 1.

## PRESSURE OF PRESSURE ROLLER

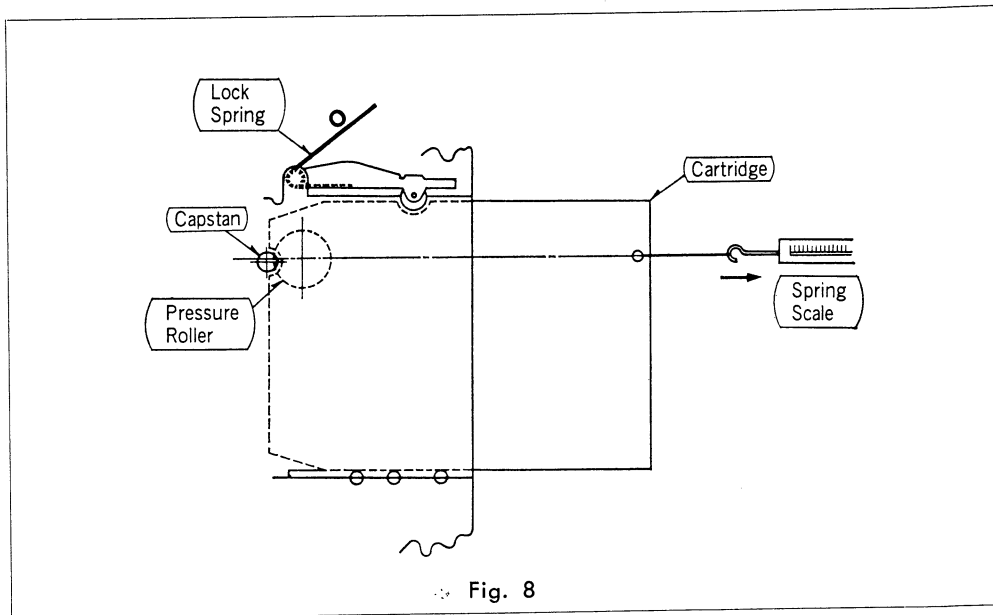

Fig. 8

Instruments required: Standard cartridge for measuring pressure of pressure roller; spring scale.

Measuring figure: Refer to fig. 8.

Measuring method: Insert the standard cartridge in the tape player, and take the me-

asurement by pulling it with the spring scale.

Standard value:  $1750 \pm 250$  gr.

## HEAD ARM ATTRACTION

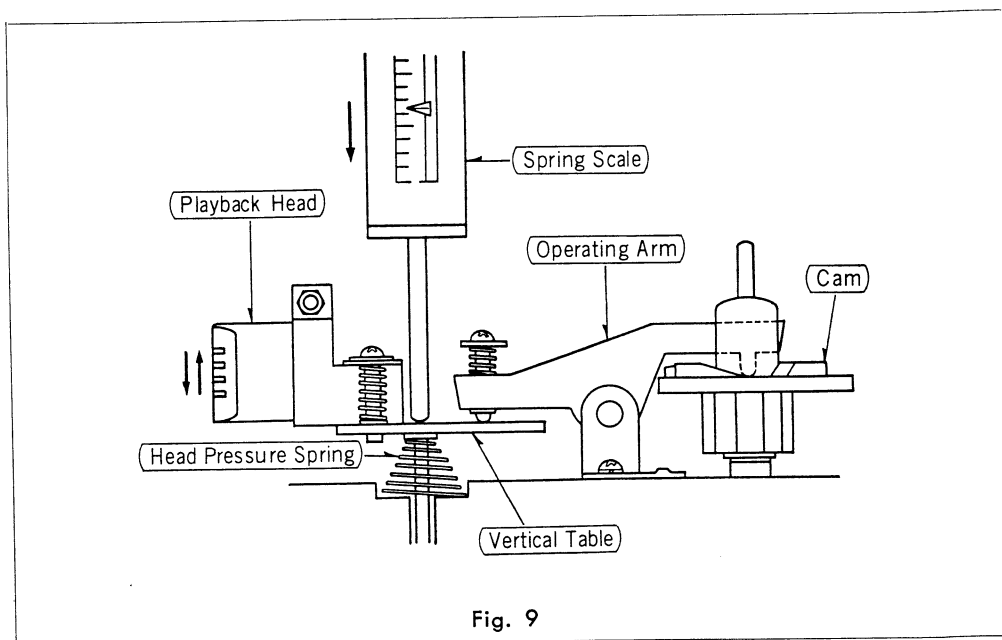

Fig. 9

Instrument required: Spring scale.

Measuring figure: Refer to fig. 9.

Measuring method: Place the set in to the mode of program 1, and the take the meas-

urement by pushing it downward with the spring scale.

Standard value:  $180 \pm 20$  gr.

## PLUNGER LOAD

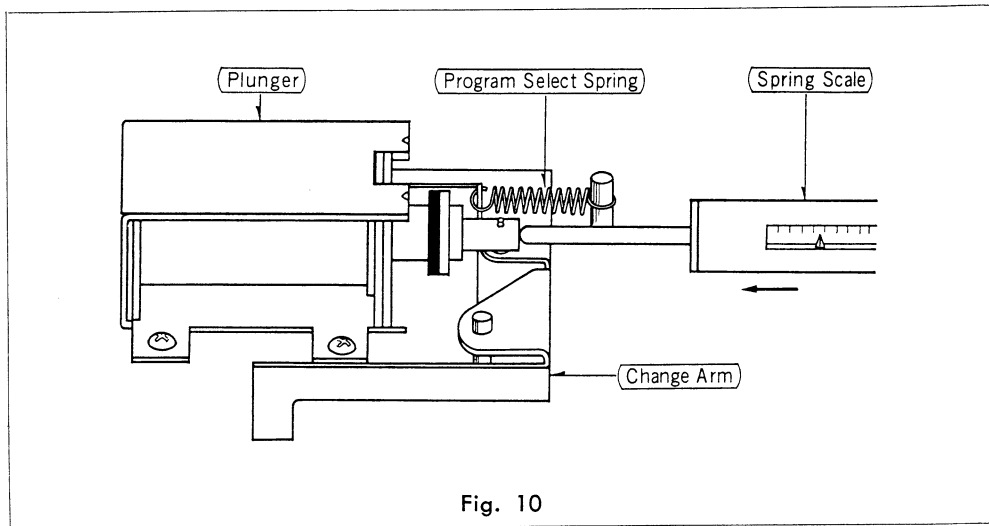

Instrument required: Spring scale.

Measuring figure: Refer to fig. 10.

Measuring method: Apply the spring scale, push in the

plunger, and measure the maximum value at the end point.  
Standard value:  $800 \pm 200$  gr.

## AMPLIFIER ADJUSTMENTS

### HEAD HEIGHT POSITION CONTROL AND AZIMUTH ADJUSTMENT

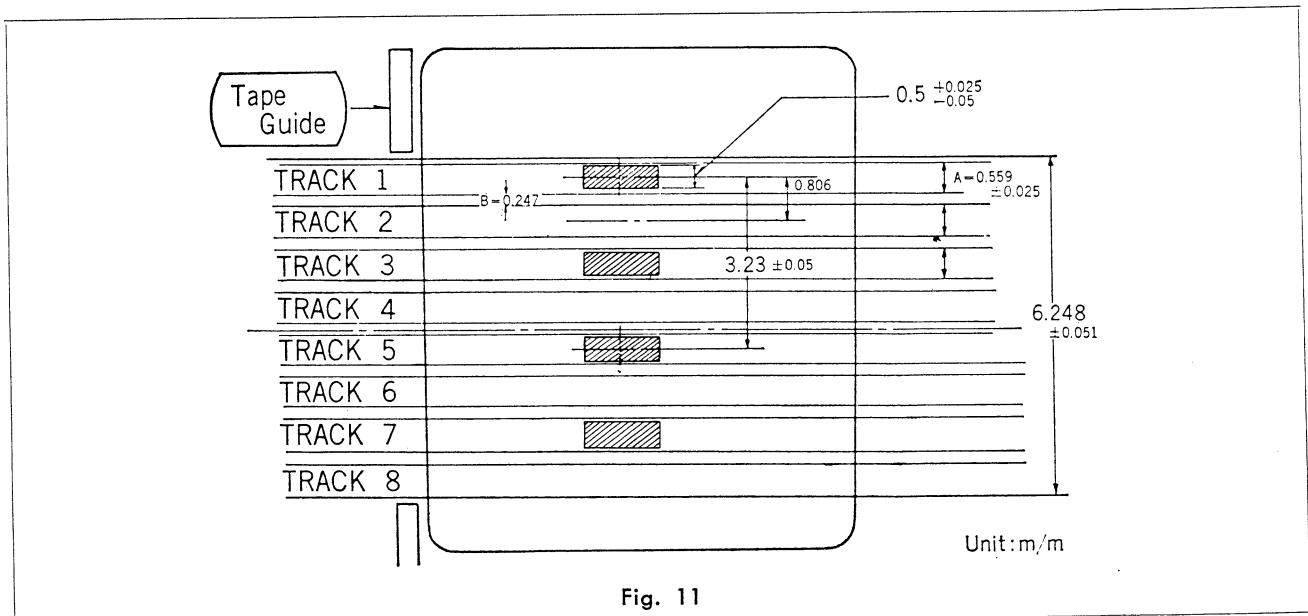

Instrument required: VTVM.

Azimuth and height position control cartridge (VTT801). Crosstalk adjustment standard tape (VTT804).

## HEAD POSITION CONTROL

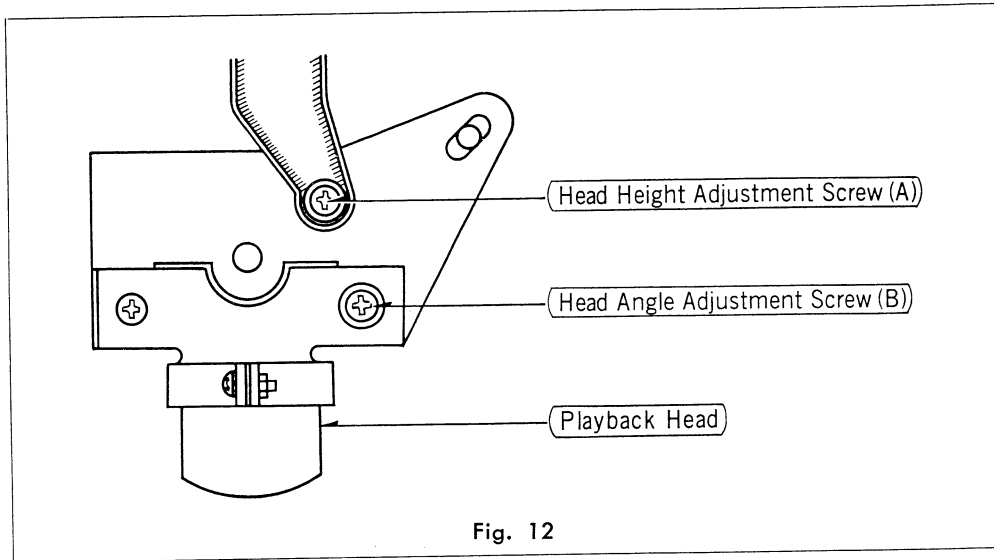

1. Place the set into program 1.
2. Make an adjustment with the unaided eye by using the head height adjust screw (A) shown in fig. 12.

so that the tape width and the head position becomes as shown in fig. 11.

---

## AZIMUTH ADJUSTMENT

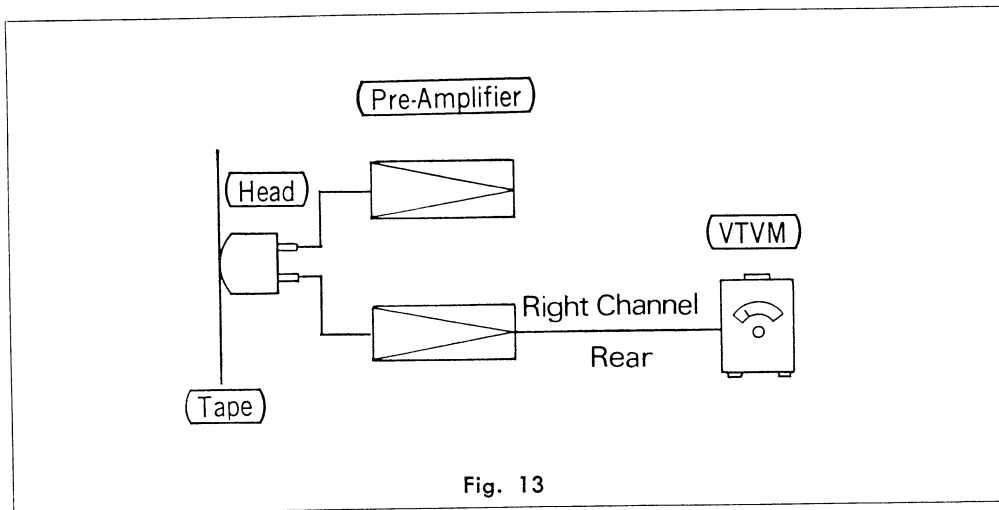

1. Set the tape player to program 2.
2. Connect a VTVM to the output of right channel in fig. 13.

3. Using either an VTT801 test tape or recorded music tape, play the tape and adjust screw B in fig. 12 for a maximum output.

## HEIGHT ADJUSTMENT

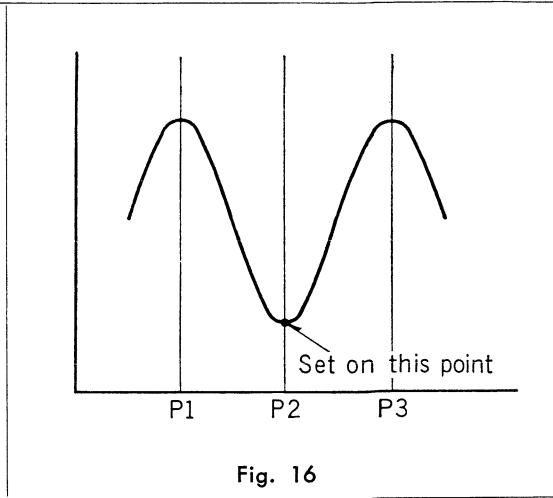
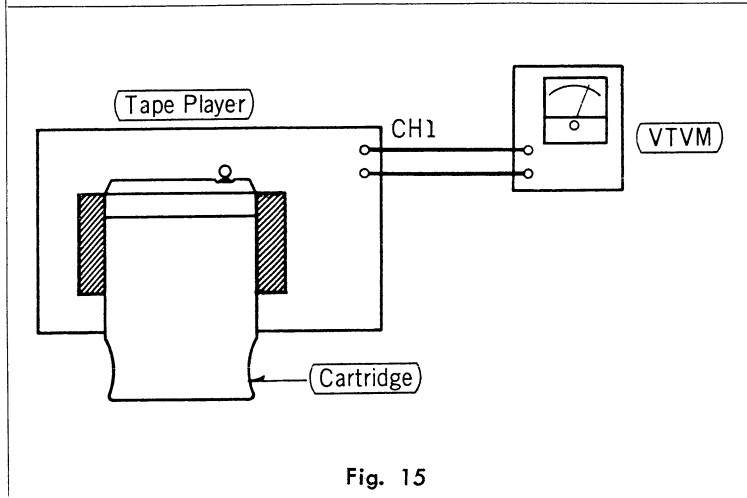
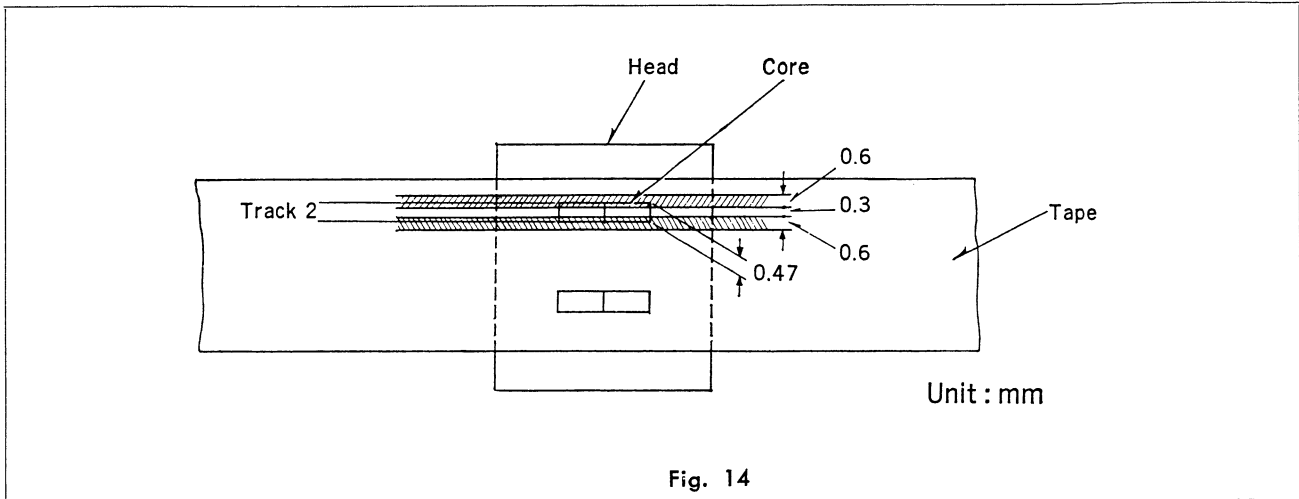

### NOTE

TEST TAPE VTT801 is recorded with a 1 kHz tone above and below track 2. When adjusting, if the tone gets louder, adjust for minimum by the turning adjustment screw in the opposite direction.

1. Set tape player to program 2.
2. Play the tape and adjust screw (fig. 12) for minimum sound on left channel or connect the equipment as shown in fig. 15.

## CROSSTALK ADJUSTMENT

### NOTE

Test tape VTT804 has 400 Hz on track 1, 3, 5, and 7, and no signal on track 2, 4, 6, and 8.

1. Using the VTVM, play each channel and measure the power ratio between each odd and even numbered track. It should be at least 35 dB.
2. If the power ratio is out of tolerance, repeat the azimuth and height adjustments.
3. Lock screws A and B in place, using glyptal or glue, Shown in fig. 12.

## STANDARD VALUE TO TEST

	ITEM	VALUE	PARTS TO BE ADJUSTED	REMARKS
1	Erase current.	0.17 V	VR7	VTVM to both ends of R71 (10Ω).
2	Recording level.	1 kHz MIC $-71 \pm 4$ dB AUX $-25 \pm 4$ dB	—	To obtain 50μA of recording current through the recording head. Stop the bias oscillation by unsoldering the wire (A) as shown on printed circuit board (page 11).
3	Recording level indicator.	0 VU on level indicator.	VR5, 6, 5', 6'	The same as above.
4	Playback amplifier gain.	$-71 \pm 4$ dB at 1 kHz	VR1 (for CH1) VR2 (for CH2) VR1' (for CH3) VR2' (for CH4)	—
5	Bias oscillation frequency.	$35 \pm 5$ kHz	—	Adjust the AF OSC to obtain a circular and stationary Lissajous' pattern on oscilloscope. The oscillation frequency is indicated by the scale of the AF OSC.



# ELECTRICAL PARTS LOCATION

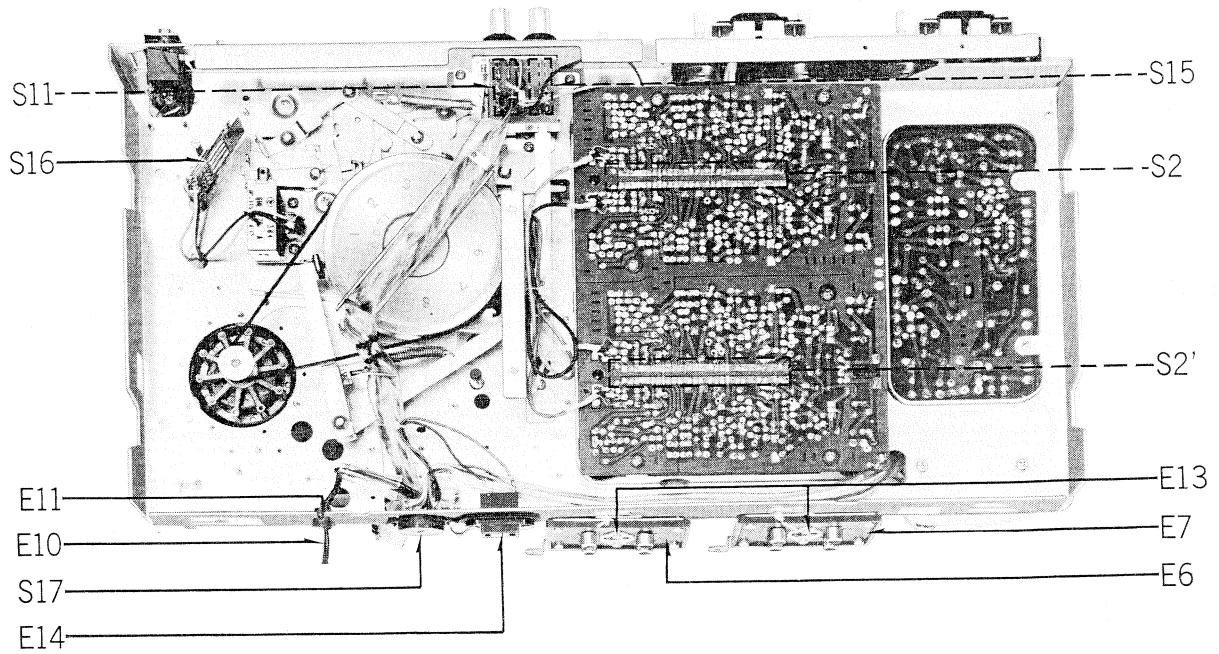
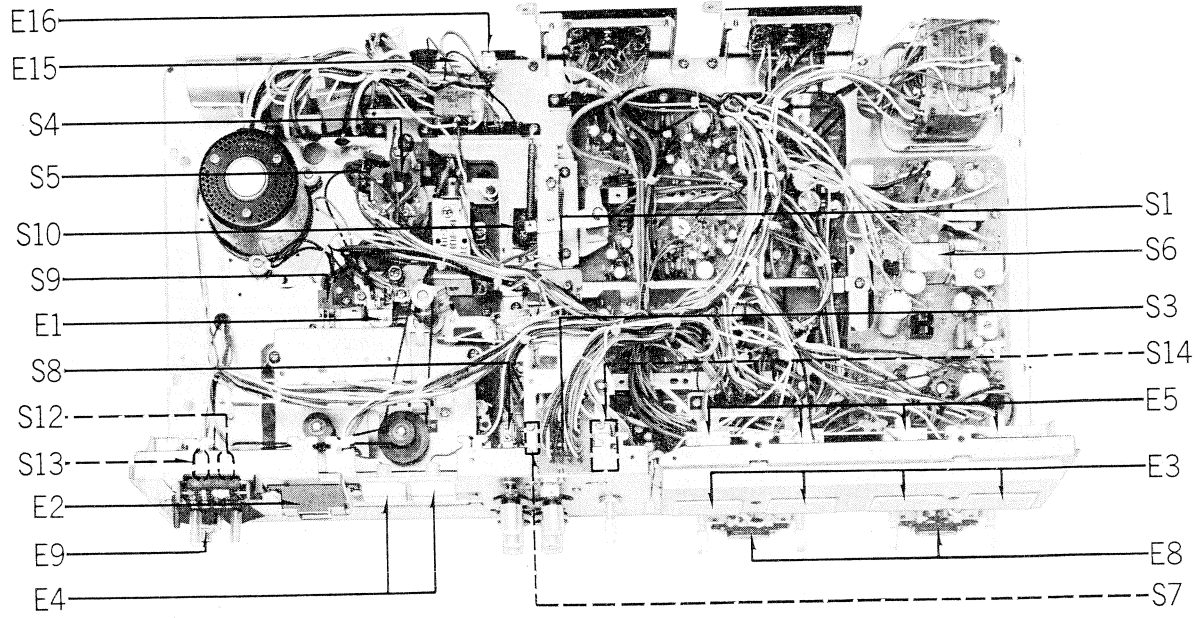

# CABINET PARTS

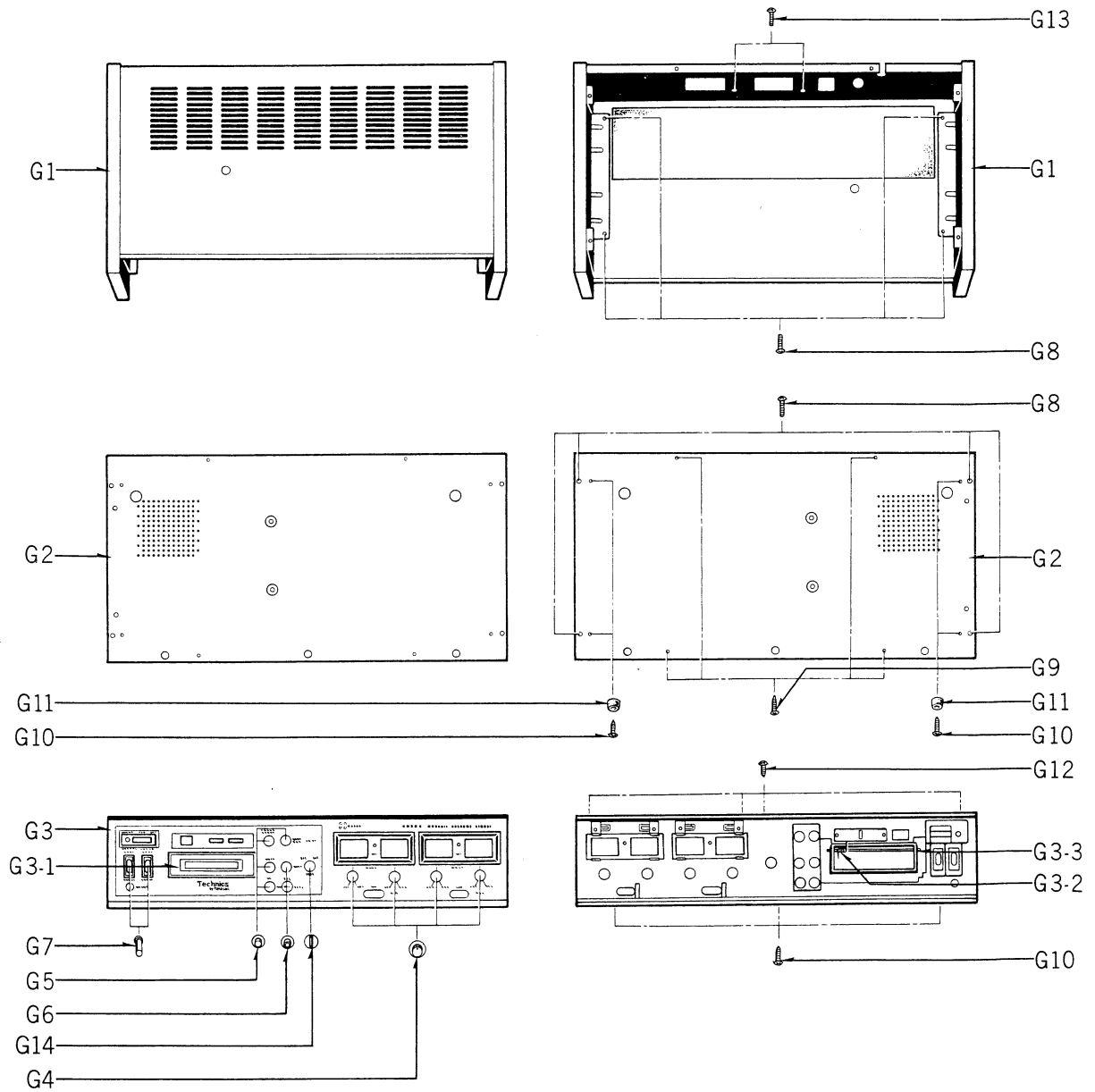

# REPLACEMENT PARTS LIST

## MODEL RS-858US (PANASONIC)

### ATTENTION:

1. Be sure to make your orders of Replacement Parts according to this List.
2. "N" indicates the New Parts.
3. "ISO" indicates the ISO Screw or Nut.

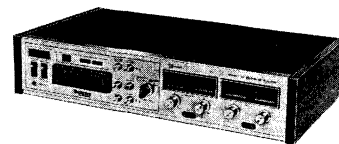

**RS-858US**

Ref. No.	Description	Part No.	Per Set (Pcs.)	Note
<b><u>MECHANICAL PARTS</u></b>				
M1	Stop Ring E3φ	XUC3FT	21	
M2	Record Operation Lever Unit	QXL0641	2	
M3	Switch Operation Spring	QBT1572M	3	
M4	Lock Release Lever	QML2239	1	
M5	Fiber Washer 4.2×9×0.25	QBK7005	4	
M6	Sub Record Lock Unit	QXL0700	1	
M7	Screw ⊕2.3×11	QH1182	4	
M8	Lock Washer 2.3φ	XWC23C	4	
M9	Actuator	QBP1468	1	
M10	Record Angle Unit-A	QXE0183	1	
M10A	Record Angle Unit-B	QXA0160	1	
M11	Tapping Screw ⊕3×8	XTB3+8B	25	
M12	Lock Release Lever (B)	QML2323	1	
M13	Record Safety Plate	QML2326	1	
M14	Lock Release Spring	QBT1571M	2	
M15	Screw ⊕3×6	XSB3+6	1	
M16	Record Lever (A) Unit	QXL0642	1	
M16A	Record Lever (B)	QML2423	1	
M17	Lock Washer 3φ	XWC3B	1	
M18	Record Adjustment Plate Unit	QXL0554	2	
M19	Record Lever (B)	QML2246	1	
M20	Screw	XSNQ0004S	1	

Ref. No.	Description	Part No.	Per Set (Pcs.)	Note
M21	Switch Holding Angle	QMA1792	1	
M22	Screw $\oplus 3 \times 10$	XTB3+10B	3	
M23	Cord Crimper	QMA1846	1	
M24	Counter Pulley	QDP1483S	1	
M25	Counter Belt	QDB0163	2	
M26	Connection Pulley (A)	QDP1484	1	
M27	Connection Pulley (B)	QDP1485	1	
M28	Tape Counter	QDC0055	1	
M29	Reinforcement Plate Unit	QXH0151	1	
M30	Eject Safety Lever Unit	QXL0475	1	
M31	Eject Safety Spring	QBN1220	1	
M32	Cartridge Guide-R	QMG0001A	1	
M33	Plunger	QME0130A	1	
M34	Program Selector Spring	QBT1705	1	
M35	Change Arm Unit	QXL0679	1	
M36	Cam	QMF1468	1	
M37	Ratchet Plate	QMF1593	1	
M38	Ratchet Spring	QBN1249	1	
M39	Operating Arm Retainer Unit	QXH0115	1	
M40	Tapping Screw $\oplus 2 \times 12$	XTN2+12B	1	
M41	Stop Spring	QBP1400	1	
M42	Head Height Adjust Screw	QHQ1088	1	
M43	Flat Washer $3\phi$	XWG3	2	
M44	Head Height Adjust Spring	QBC1167	1	
M45	Fiber Washer $4.2 \times 9 \times 0.5$	QBK7005	7	
M46	Operation Arm	QML2058	1	
M47	Sems Screw $\oplus 3 \times 6$	XYN3+C6S	6	
M48	Screw $\ominus 3 \times 10$	XSN3-10	1	
M49	Head Holding Angle	QMH1184	1	

Ref. No.	Description	Part No.	Per Set (Pcs.)	Note
M50	Head Angle Adjust Spring	QBC1166	1	
M51	Vertical Table Unit	QXH0113	1	
M52	Head Pressure Spring	QBC1168	1	
M53	Head Base Plate Unit with S9	QXK1313	1	
M54	Motor Assembly	24AQSCZ61P	1	
M55	Cartridge Guide-L Assembly	QXQ0065A	1	
M56	Motor Pulley Set Screw	XXE3D5FZS	2	
M57	Motor Pulley-60 Hz	QDP1503S	1	
(M57)	Motor Pulley-50 Hz	QDP1502S	(1)	
M58	Plunger	QME0129A	1	
M59	Tapping Screw $\oplus 3 \times 6$	XTB3+6B	2	
M60	Lock Release Lever	QML2404	1	
M61	Lock Release Lever Spring	QBN1282	1	
M62	Eject Plate Unit	QXH0138	1	
M63	Sems Screw $\oplus 3 \times 4$	XYN3+C4S	5	
M64	Return Spring	QBT1576M	1	
M65	Eject Spring	QBN1177	1	
M66	Toggle Plate-C	QMF1435A	1	
M67	Right Toggle Plate	QMF1432	1	
M68	Left Toggle Plate	QML2605	1	
M69	Lock Arm Unit	QXH0139	1	
M70	Toggle Plate Unit	QXL0519	1	
M71	Lock Lever Unit	QXL0704	1	
M72	Lock Lever Spring	QBT1648	1	
M73	Sems Screw $\oplus 2.6 \times 6$	XYN26+C6	2	
M74	Flat Washer 2.6 $\phi$	XWG26	2	
M75	Flywheel Retainer Unit	QXH0154	1	
M76	Flywheel Unit	QXF0084	1	
M77	Flywheel Belt	QDB0170	1	

Ref. No.	Description	Part No.	Per Set (Pcs.)	Note		
M78	Poly Washer 6.2×13×0.25	QBJ3299	2			
M79	Tapping Screw ⊕3×12	XTB3+12B	3			
M80	Screw ⊕3×6	XST3+6	3			
M81	Capstan Metal Unit	QXQ0055A	1			
M83	Pause Angle Unit	QXE0188	1			
M84	Main Brake Lever	QML2542	1			
M85	Brake Lever	QML2543	1			
M86	Main Brake Lever Spring	QBT1689	1			
M87	Brake Shoe	QBG1414	1			
M88	Reinforcement Angle	QMA2063S	1			
M89	Brake Rod	QMR1319	1			
M90	Brake Rod Spring	QBT1690	1			
M91	FF Release Lever	QML2240	1			
<b><u>RESISTORS</u></b>						
R1, 2, 1', 2'	Carbon Resistor	100 KΩ	1/4 W	ERD14VJ104	4	
R3, 4, 3', 4'	"	560Ω	1/4 W	ERD14TJ561	4	
R5, 6, 5', 6'	"	100Ω	1/4 W	ERD14TJ101	4	
R7, 8, 11, 12, 33, 34, 7', 8', 11', 12', 33', 34'	"	5.6 KΩ	1/4 W	ERD14VJ562	12	
R9, 10, 9', 10'	"	56 KΩ	1/4 W	ERD14VJ563	4	
R13, 14, 21, 22, 35, 36, 13', 14', 21', 22', 35', 36'	Carbon Resistor	10 KΩ	1/4 W	ERD14VJ103	12	
R15, 16, 15', 16'	"	100Ω	1/4 W	ERD14VJ101	4	
R17, 18, 27, 28, 74, 75, 96, 97, 17', 18', 27', 28'	"	2.2 KΩ	1/4 W	ERD14VJ222	12	
R19, 20, 19', 20'	"	15 KΩ	1/4 W	ERD14VJ153	4	
R23, 24, 25, 26, 87, 88, 73, 23', 24', 25', 26', 87', 88'	"	1.5 KΩ	1/4 W	ERD14VJ152	13	
R29, 30, 29', 30'	Carbon Resistor	390 KΩ	1/4 W	ERD14VJ394	4	
R31, 32, 82, 31', 32'	"	8.2 KΩ	1/4 W	ERD14VJ822	5	

Ref. No.	Description	Part No.	Per Set (Pcs.)	Note
R37, 38, 47, 48, 55, 56, 37', 38', 47', 48', 55', 56'				
	Carbon Resistor 33 K $\Omega$ 1/4 W	ERD14VJ333	12	
R39, 40, 39', 40'	" 33 $\Omega$ 1/4 W	ERD14VJ330	4	
R41, 42, 41', 42'	" 2.7 K $\Omega$ 1/4 W	ERD14VJ272	4	
R43, 44, 45, 46, 43', 44', 45', 46'				
	Carbon Resistor 4.7 K $\Omega$ 1/4 W	ERD14VJ472	8	
R49, 50, 61, 62, 49', 50', 61', 62'				
	" 12 K $\Omega$ 1/4 W	ERD14VJ123	8	
R51, 52, 51', 52'	" 120 $\Omega$ 1/4 W	ERD14VJ121	4	
R53, 54, 65, 66, 53', 54', 65', 66'				
	" 680 $\Omega$ 1/4 W	ERD14VJ681	8	
R57, 58	" 3.3 K $\Omega$ 1/4 W	ERD14TJ332	2	
R57', 58', 80	Carbon Resistor 3.3 K $\Omega$ 1/4 W	ERD14VJ332	3	
R59, 60, 91, 92	" 82 K $\Omega$ 1/4 W	ERD14VJ823	4	
R63, 64, 63', 64'	" 3.9 K $\Omega$ 1/4 W	ERD14VJ392	4	
R67, 83, 201	" 470 $\Omega$ 1/4 W	ERD14VJ471	3	
R68	" 220 K $\Omega$ 1/4 W	ERD14VJ224	1	
R69, 70	Carbon Resistor 4.7 $\Omega$ 1/4 W	ERD14VJ4R7	2	
R71	" 10 $\Omega$ 1/4 W	ERD14TJ100	1	
R72	Solid Resistor 10 K $\Omega$ 1/2 W	ERC12GM103	1	
R76	" 470 $\Omega$ 1/2 W	ERC12GM471	1	
R77	Wire-wound Resistor 0.75 $\Omega$ 1/2 W	ERM12PJR75	1	
R78	Solid Resistor 220 $\Omega$ 1 W	ERC1GM221	1	
R79	" 10 $\Omega$ 1/2 W	ERC12GM100	1	
R81	Carbon Resistor 150 $\Omega$ 1/4 W	ERD14TJ151	1	
R84, 98	" 270 $\Omega$ 1/4 W	ERD14VJ271	2	
R93	" 39 $\Omega$ 1/4 W	ERD14VJ390	1	
R94	Carbon Resistor 56 $\Omega$ 1/4 W	ERD14VJ560	1	

Ref. No.	Description	Part No.	Per Set (Pcs.)	Note
<b><u>VARIABLE RESISTORS</u></b>				
VR1, 2, 1', 2'	Semi-fixed Variable Resistor 10 K $\Omega$ (B)	QVL00AA00B14	4	
VR3, 4, 3', 4'	Variable Resistor 5 K $\Omega$ (A)	EVCB7AK30A53	4	
VR5, 6, 5', 6'	Semi-fixed Variable Resistor 5 K $\Omega$ (B)	QVL00AA00B53	4	
VR7	" 20 K $\Omega$ (B)	QVL00AA00B24	1	
<b><u>CAPACITORS</u></b>				
C1, 2, 17, 18, 33, 34, 1', 2', 17', 18', 33', 34'	Mylar Capacitor 0.001 $\mu$ F	ECQM05102MZB	12	
C3, 4, 9, 10, 21, 22, 23, 24, 27, 28, 35, 36, 43, 44, 3', 4', 9', 10', 21', 22', 23', 24', 27', 28', 35', 36', 43', 44'	Electrolytic Capacitor 3.3 $\mu$ F	ECEA25V3R3L	28	
C5, 6, 7, 8, 19, 20, 5', 6', 7', 8', 19', 20'	" 33 $\mu$ F	ECEA6V33L	12	
C11, 12, 11', 12'	Mylar Capacitor 0.0047 $\mu$ F	ECQM05472MZB	4	
C13, 14, 13', 14'	" 0.039 $\mu$ F	ECQM05393MZB	4	
C15, 16, 15', 16'	Electrolytic Capacitor 0.22 $\mu$ F	ECEA25VR22M	4	
C25, 26, 31, 32, 25', 26', 31', 32'	" 220 $\mu$ F	ECEA6V220L	8	
C29, 30, 29', 30'	" 10 $\mu$ F	ECEA16V10L	4	
C37, 38, 37', 38'	Mylar Capacitor 0.0018 $\mu$ F	ECQM05182MZB	4	
C39, 40, 39', 40'	" 0.0015 $\mu$ F	ECQM05152MZB	4	
C41, 42, 41', 42'	Electrolytic Capacitor 33 $\mu$ F	ECEA10V33L	4	
C45, 46, 45', 46'	" 33 $\mu$ F	ECEA16V33L	4	
C47, 48, 47', 48'	Mylar Capacitor 0.022 $\mu$ F	ECQM05223MZ	4	
C50	Electrolytic Capacitor 220 $\mu$ F	ECEA16V220L	1	
C51	Ceramic Capacitor 1000 pF	ECKD1H102PF2	1	
C52, 54, 59	Mylar Capacitor 0.1 $\mu$ F	ECQM05104MZB	3	
C53	Styrol Capacitor 2200 pF	ECQS1222JZ	1	
C55	Mylar Capacitor 0.056 $\mu$ F	ECQM05563MZB	1	
C56, 81	Electrolytic Capacitor 100 $\mu$ F	ECEA16V100L	2	
C57	Styrol Capacitor 1200 pF	ECQS5122J	1	



Ref. No.	Description	Part No.	Per Set (Pcs.)	Note
C58, 62, 63, 76, 77	Electrolytic Capacitor 470 $\mu$ F	ECEA16V470L	5	
C60, 68	" 1000 $\mu$ F	ECEA25V1000	2	
C61	" 1 $\mu$ F	ECEA50V1L	1	
C64	" 47 $\mu$ F	ECEA16V47L	1	
C65	" 1000 $\mu$ F	ECEA16V1000L	1	
C70	MP Capacitor	MP250V3U	1	
C80	Electrolytic Capacitor 330 $\mu$ F	ECEA10V330L	1	
<b><u>TRANSISTORS</u></b>				
Tr1, 2, 1', 2'	Transistor	2SB348 $\text{\textcircled{Q}}$	4	
Tr3, 4, 7, 8, 3', 4', 7', 8'	"	2SB346	8	
Tr5, 6, 5', 6'	"	2SA101C $\text{\textcircled{Q}}$	4	
Tr9, 10, 9', 10'	"	2SB172A	4	
Tr11	"	2SB178 (O,P,A,B,Z,M,N,Q)	1	
Tr12	Transistor	2SB175B	1	
Tr13	"	2SC1096L(K,L)	1	
Tr14	"	2SB324(D,E,F)	1	
<b><u>DIODES &amp; RECTIFIERS</u></b>				
D1, 2, 1', 2'	Diode	OA90Z	4	
D3, 4, 5, 3', 4'	Silicon Diode	1S1211	5	
D6, 8, 9	"	S0501	3	
D7	"	FR202	1	
D10, 11	Silicon Rectifier	10DC1	2	
D12, 13	Silicon Rectifier	10DC1R	2	
<b><u>TRANSFORMERS</u></b>				
T1, 2, 1', 2'	Headphone Transformer	QLA0349	4	
T3	Oscillator Transformer	QLB0141	1	
T4	Power Transformer	QLP0721	1	

Ref. No.	Description	Part No.	Per Set (Pcs.)	Note
<b><u>COILS</u></b>				
L1, 2, 1', 2'	Trap Coil	ELM10S206	4	
L3	Erase Head Dummy Coil	ELQ4C1	1	
L4	Oscillator Output Transformer	QLB0138	1	
<b><u>COMBINATION PART</u></b>				
CR1,2,3,4,5,6	CR Combination	QCR0008	6	
<b><u>THERMISTOR</u></b>				
TH1	Thermistor	QVM302A	1	
<b><u>SWITCHES</u></b>				
S1	Micro Switch (Power ON/OFF)	QSM0037	1	
S2, 2'	Slide Switch (Record/Playback)	QSS1146	2	
S3	Push Switch (2/4 Channel)	QSW0204S	1	
S4	Rotary Switch (Program Indicator)	QSR0012A	1	
S5	Micro Switch (Plunger)	QSM0037	1	
S6	Relay Switch	QSK0123A	1	
S7	Push Switch (Manual Eject)	QSW0118S	1	
S8	Push Switch (Program Select)	QSW0116S	1	
S9	Sensing Switch	(Ref. M53)	(1)	
S10	Micro Switch (Relay)	QSM0040A		
S11 & 15	Push Switch (FF/Pause)	QSW0119S	1	
S12	Lever Switch (AC OUT Select)	QST0039S	1	
S13	Lever Switch (Headphone Select)	QST0040S	1	
S14	Rotary Switch (Operation Select)	ESRE244K25Z	1	
S16	Leaf Switch (Cartridge)	QSB0204	1	
S17	Rotary Switch (Voltage Select)	QSR0004B	1	

Ref. No.	Description	Part No.	Per Set (Pcs.)	Note
<b><u>ELECTRICAL PARTS</u></b>				
E1	Head (Rec/Play/Erase)	QWY8004	1	
E2	Program Indicator	XAMQ15S	1	
E3	VU Meter	QSL1016L	4	
E4	Pilot Lamp	XAMQ11P300	2	
E5	”	XAMQ16P300	6	
E6	Jack Plate-1 Assembly	QEJ0256	1	
E7	Jack Plate-2 Assembly	QEJ0257	1	
E8	Microphone Jack	QJA0427	2	
E9	Headphone Jack	QJA0229	1	
E10	AC Power Cord	QFC1041	1	
E11	Heyco Bushing	QTD1126A	1	
E12	Screw	XSNQ0004S	6	
E13	DIN Socket	QJS0723	2	
E14	AC Socket (AC Out)	QJS0317	1	
E15	Fuse 1A	XBA1E10NR3	1	
E16	Fuse Holder	QTF1033	1	
<b><u>CABINET PARTS</u></b>				
G1	Main Body Case Assembly	QYB0349S	1	
G2	Bottom Plate	QKU1564	1	
G3	Panel Assembly	QYP0459	1	
G3-1	Cartridge Lid	QKF1432	1	
G3-2	Cartridge Lid Spring	QBC1090	1	
G3-3	Cartridge Lid Rod	QMR1075	1	
G4	Volume Control Knob	QYT0286K	4	
G5	Button Assembly	QYT0114	5	
G6	Record Button	QXB0143	1	
G7	See-Saw Knob	QGT3045S	2	

Ref. No.	Description	Part No.	Per Set (Pcs.)	Note
<b><u>ELECTRICAL PARTS</u></b>				
E1	Head (Rec/Play/Erase)	QWY8004	1	
E2	Program Indicator	XAMQ15S	1	
E3	VU Meter	QSL1016L	4	
E4	Pilot Lamp	XAMQ11P300	2	
E5	”	XAMQ16P300	6	
E6	Jack Plate-1 Assembly	QEJ0256	1	
E7	Jack Plate-2 Assembly	QEJ0257	1	
E8	Microphone Jack	QJA0427	2	
E9	Headphone Jack	QJA0229	1	
E10	AC Power Cord	QFC1041	1	
E11	Heyco Bushing	QTD1126A	1	
E12	Screw	XSNQ0004S	6	
E13	DIN Socket	QJS0723	2	
E14	AC Socket (AC Out)	QJS0317	1	
E15	Fuse 1A	XBA1E10NR3	1	
E16	Fuse Holder	QTF1033	1	
<b><u>CABINET PARTS</u></b>				
G1	Main Body Case Assembly	QYB0349S	1	
G2	Bottom Plate	QKU1564	1	
G3	Panel Assembly	QYP0459	1	
G3-1	Cartridge Lid	QKF1432	1	
G3-2	Cartridge Lid Spring	QBC1090	1	
G3-3	Cartridge Lid Rod	QMR1075	1	
G4	Volume Control Knob	QYT0286K	4	
G5	Button Assembly	QYT0114	5	
G6	Record Button	QXB0143	1	
G7	See-Saw Knob	QGT3045S	2	

Ref. No.	Description	Part No.	Per Set (Pcs.)		Note
G8	Screw $\oplus 4 \times 8$	XSN4+8RS	10		
G9	Tapping Screw $\oplus 3 \times 8$	XTV3+8BR	4		
G10	Tapping Screw $\oplus 3 \times 8$	XTV3+8B	7		
G11	Rubber Foot	QKA1050	4		
G12	Screw $\oplus 3 \times 8$	XTS3+8B	5		
G13	Screw $\oplus 3 \times 6$	XSN3+6FZS	2		
G14	Selector Knob	QYT0287K	1		
	<b><u>ACCESSORIES</u></b>				
A1	Connection Cord-G	RP8125 (QEB0060P)	4		
A2	Head Cleaning Bar	QFQ1025	1		
A3	Demonstration Tape	QFT80GPADZ	1		
A4	Instruction Book	QQT0571	1		
	<b><u>PACKINGS</u></b>				
P1	Inside Packing	QPN2997	1		
P2	Inner Cushion	QPN2831	2		
P3	Poly Sheet	QPQ1082	2		
P4	Spacer	QPN2907	1		
P5	”	QPN2910	1		
P6	Dust Cover	XZB70 $\times$ 60A05	1		